

Welcome to



HIS UNIVERSITY

School Catalog

July 1, 2018 - June 30, 2019

1245 West 6th Street * Corona, California 92882

PHONE: (951) 372-8080, 8085

FAX: (951) 372-8070

This catalog can be downloaded at:

Website: www.hisuniversity.org

The printed copy of this catalog will be sent upon request via mail.

Please contact the school administrative office at below email.

Email: hisuniv@yahoo.com

Pay attention and

Listen to the

Sayings of the wise;

Apply your heart.

To what I teach,

For it is pleasing when you

Keep them in your heart

And have all of them ready

On your lips.

Proverbs 22:17-18

A Message from the President

Dear beloved friends and potential students:

Greetings in the name of Jesus Christ, our Lord!

It would be my great privilege to have you or someone you care about as a student at HIS University, a unique school training family ministry leaders by providing a quality education in the field of Christian education and Christian counseling. HIS University seeks to train excellent Christian leaders well equipped with knowledge, intelligence, character, skill and experience for their professional and lay positions in order that each participant may serve God and His people.

His University faculty members and staff are ready to serve you who are interested in academic excellence and quality ministry preparation for **HIS** Kingdom, **HIS** glory, with **HIS** resources and by **HIS** power. I am sure that your experience at HIS University will be an unforgettable one as we provide you with an integrated education: eastern and western. Furthermore, you will become knowledgeable in sound Biblical theology, deep intellectual theory, and obtain practical field experience.

We believe you are not here by chance but by the providence of God who has a beautiful plan for your life. Share your vision for world mission, experience personal growth in Christian character, and enjoy new friends that will last a lifetime!

Sincerely yours,



Eun Soon Yang, Ph.D., MFT
President

Vision

***HIS University: Educating and Training
His Family Ministry Specialists.***



Our aim is to endow each student with a vision of world mission based upon a fundamental knowledge of biblical principles. We are determined to cultivate devoted leaders who will build healthy families and enhance the quality of other people's lives. With skills for developing positive human relations and cross-cultural education experience, students will be ready to efficiently deal with individual problems and family crisis.

Reflected below are characteristics descriptive of HIS University graduates:

1. Competent ***Family Ministers and Missionaries*** with an understanding that all people are created in God's image, and that His desire is that everyone belongs to His family. Graduates have a Christian worldview and concrete faith in God that makes them willing and capable in the ministry of restoring marriage and family relationships.
2. Professional ***Family Counselors*** who can efficiently cope with individual and family crisis and well trained to work within churches, schools, Christian and secular organizations.
3. Capable ***Family Educators*** with a strong biblical background who will train others in all stages of life.

Special Characteristics of HIS University

1. While Korean is the primary language of instruction, some classes are in English with a Korean translator and a few MFT classes are in English. Some textbooks are in Korean while others are in English.

Korean language proficiency is determined by a pre-enrollment oral interview. English proficiency for the MFT Program is required. A translator may be provided for students for a fee. See the Registrar's office for more information.

2. Marriage and Family Therapy graduates are prepared for the California state exam for obtaining a license as a Marriage and Family Therapist (LMFT) administered by the California State Board of Behavioral Sciences (BBS) upon graduation. While most of the MFT classes are taught in Korean, the BBS Licensing Exam is in English, thus the MFT Program has an English Proficiency requirement.
3. Students participate in experiential learning in the classroom.

Table of Contents

A MESSAGE FROM THE PRESIDENT	iii
HIS UNIVERSITY VISION	iv
TABLE OF CONTENTS	v
DEGREES AND DIPLOMAS	1
ADMISSIONS PROCESS AND QUALIFICATION	2
FACULTY	3
ACADEMIC INFORMATION	5
Academic Calendar Year 2018-2019	5
Academic GPA & Probation	5
Application Procedures	6
Bureau for Private Postsecondary Education (BPPE).....	6
Challenge Exams and Achievement Tests	7
Grading System	7
High School Diploma or Equivalent	8
Life Experience.....	8
Program Length.....	8
Termination	8
Units/Credits Defined	8
Units/Credits Transfer	8
Visas for Students.....	9
Withdrawal and Leave-of-Absence	9
Withdrawal Grades.....	9

FINANCIAL INFORMATION	9
Financial Aid.....	9
Financial Due Dates.....	9
Financial - General	9
Financial Loans	10
Program Tuition	10
Refund Policy.....	11
Right to Cancel.....	12
STRF – Student Tuition Recovery Fund	12
GENERAL INFORMATION.....	13
Accreditation Status.....	13
Changes in the Catalog	13
Community Agreement.....	13
Education Site Procedure	13
Facilities and Equipment	13
Grievance Procedure.....	13
HIS University Faith and Practice Statement	14
HIS University Moral Commitment to Ethical Values and Standards.....	14
Housing.....	15
Library	15
Non-Discrimination Policy	15
Placement/Out-reach Services	15
Plagiarism	15
Student Code of Conduct.....	15

Student Records.....	16
Student Services	17
Transcripts and Records.....	17
ACADEMIC PROGRAMS	17
Doctor of Philosophy in Marriage and Family Ministry	17
Doctor of Education in Christian Education and Counseling.....	18
Master of Arts in Marriage and Family Therapy	20
Master of Arts in Christian Counseling.....	22
Master of Arts in Christian Education	23
Bachelor of Arts in Counseling	24
Associate of Arts Degree in Counseling	25
Diploma in Peer Christian Counseling.....	27
COURSE DESCRIPTIONS	28
Doctor of Philosophy in Family Ministries	28
Doctor of Education in Christian Education and Counseling.....	29
Master of Arts in Marriage and Family Ministry.....	31
Master of Arts in Christian Counseling	33
Master of Arts in Christian Education	35
Bachelor of Arts in Counseling	36
Associate of Arts in Counseling.....	38
Diploma in Peer Christian Counseling	39
ADMISSION AND EVALUATION PROCESS OF FOREIGN STUDENTS.....	41
CAMPUS MAP	43
COMMUNITY AGREEMENTS.....	44

FAITH STATEMENT 45

HIS University Degrees and Diplomas

Degree Title 학위명	Degree Focus 전공
Doctor of Philosophy Degree (Ph.D.) 철학박사	Family Ministry 가정사역
Doctor of Education Degree (Ed.D.) 교육학박사	Christian Education and Counseling 교육과상담
Master of Arts Degrees 문학석사	Marriage and Family Therapy 결혼과가족치료 ----- Christian Counseling 기독교상담 ----- Christian Education 기독교교육
Bachelor of Arts Degree 문학학사	Counseling 상담학학사
Associate Degree 전문대학사	Counseling 상담전문대학사
Diploma Title 디플로마 자격과정	Diploma Focus 전공
Peer Christian Counseling Diploma 상담자 디플로마	Peer Christian Counseling 기독교상담

Admissions Process and Qualification

Qualifications

Ph.D. in Family Ministry

- * Completion of Master's Degree
- * GPA 3.0 in Master's Studies
- * Field Experience no less than 3years

Doctor of Education

- * Completion of Master's Degree
- * GPA 3.0 in Master's Studies

Master's Degrees

- * Completion of undergraduate degree
- * 80+ TOEFL Score, PBT550 or IBT or Equivalent (MFT Degree Only)

Bachelor's Degree

- * Completion of AA or more than 60 units at College or Equivalent

Associate's Degree, Diploma

- * Completion of High School or G.E.D.

Commented [DB1]: What is correct? 80+ score? Please explain.

Required Documents

Doctoral Degrees

- * HIS University Application
- * Master's Degree and Official Transcripts
- * Two Letters of Recommendation
- * Personal Introduction

Master's Degrees

- * HIS University Application
- * Bachelor's Degree and Official Transcripts
- * Two Letters of Recommendation
- * Personal Introduction

Bachelor's Degree

- * HIS University Application
- * High School Diploma, GED or Equivalency or AA Transcript
- * Two Letters of Recommendation
- * Personal Introduction

Associate's Degree

- * HIS University Application
- * High School Diploma, GED or Equivalency
- * Personal Introduction

Diploma

- * HIS University Application
- * High School Diploma, GED or Equivalency
- * Personal Introduction

HIS University Faculty Members

Full-time Faculty/Administration

Eun Soon Yang, Ph.D., LMFT (President/CEO)

Ph.D. Intercultural Education and Family Ministry, BIOLA University
M.A. Cross-Cultural Studies, Fuller Theological Seminary
B.A. English, Hankuk University of Foreign Studies

Boo Un Oh, Ph.D. (Chief Operations & Finance Officer and Education Dept. Director)

Ph.D. Youth Leadership, MyongJi University
M.A. Christian Ethic, MyongJi University
B.A. English Education, Chongshin University

Donna Brown, Ph.D. (Chief Academic Officer)

Ph.D. Intercultural Education, BIOLA University
M.A. Biblical Literature, Assemblies of God Theological Seminary
B.A. Elementary Education, Louisiana State University of New Orleans
A.A. Practical Theology, Christ for the Nations Institute

Kay H. Kim, Ph.D., LMFT (Counseling Department Director)

Ph.D. Family Ministry, HIS University
M.A. Marriage and Family Therapy, HIS University
A.A. FIDM (Fashion Institute of Design and Merchandising) Marketing
B.A. English Education, Ewha Woman's University

Ji Yeon Kim, Ph.D. (Undergraduate Studies Department Director)

Ph.D. Family Ministry, HIS University
M.A. Intercultural Studies, Fuller Theological Seminary
B.A. Christian Education, Korea Baptist Theological University/Seminary

Min Sook Kim, Ph.D. (Foreign Students Director)

Ph.D. Family Ministry, HIS University
Ph.D. Chemistry, University of Miami
M.S. Chemistry, Pusan National University
B.S. Chemistry, Pusan National University

Kathleen P. Baxter, R.N. (Registrar & Administrative Assistant)

B.S. Healthcare Management, American Century University
R.N. St. Anthony Medical Center College of Nursing

Adjunct Professors

Byun, Hyun Ok, Ed.D.

Ed.D. Education in Counseling, HIS University
M.A. Family Ministry and Counseling, Cheonan University
B.A. Business Administration, Ewha Woman's University

Choi, Jeong Lan, Ed.D.

Ed.D. Education in Counseling, HIS University
M.A. Family Ministry and Counseling, Cheonan University
B.A. Food and Nutrition, Hanyang University

Kim, Ok Nam, Ph.D.

Ph.D. Family Ministry, HIS University
M.A. Education, Chonnam National University
B.A. Art Education, Chosun University

Kim, Sun Young, Ed.D.

Ed.D. Education in Counseling, HIS University
M.A. Family Ministry and Counseling, Cheonan University
B.A. Food and Nutrition, Sejong University

Lee, Eun Soon, Ph.D.

Ph.D. Counseling and Clinical Psychology, Ewha Woman's University
M.A. Developmental Psychology, Ewha Woman's University
B.A. Educational Psychology, Ewha Woman's University

Lee, Hyun Sook, Ph.D.

Ph.D. in Family Ministry, HIS University
M.A. Family Ministry and Counseling, Cheonan University
B.A. Korean Language and Literature, the Catholic University of Korea

McMains, Y. Kristina, Ph.D.

Ph.D. Family Ministry, HIS University
M.A. Christian Counseling, HIS University
B.A. English Literature, Ewha Women's University

Shin, Eun Seob, Ed.D.

Ed.D. Education in Counseling, HIS University
M.A. Family Ministry and Counseling, Cheonan University
B.A. Korean Language, National Open University
A.A. Dental Hygiene, Shingu University

Winer, Burt, Ph.D., LMFT, MBA

Ph.D. Family Ministry, HIS University
M.A. Psychology, Pepperdine University
MBA Business, Pepperdine University
B.S. California State University at LA

ACADEMIC INFORMATION

Academic Calendar Year 2018-2019

WINTER INTENSIVES

First Day of WINTER Intensive	Monday	August 6
Last Day of WINTER Intensive	Saturday	August 11

FALL SEMESTER 2018

Last day to Enroll for F1 Students (register)	Friday	July 20
Last day of Enrollment for Local Students	Friday	August 30
Labor Day Holiday	Monday	September 3
First Day of Class	Monday	September 10
Last Day to Add Classes	Thursday	September 20
Thanksgiving Holiday	Monday-Sunday	November 19-25
Last Day of Class	Thursday	December 13
Christmas/New Year's Holiday	Monday	December 17

SUMMER INTENSIVES

Summer Intensive for Doctoral Students	Thursday-Saturday	January 17-26
Summer Intensive for Master Students	Monday-Saturday	January 21-26
Summer Intensive for Undergraduate Students	Tuesday-Thursday	January 29-February 7

SPRING SEMESTER 2019

Last day to Enroll for F1 Students (register)	Monday	January 21
Last day of Enrollment for Local Students	Thursday	February 7
First Day of Class	Monday	February 11
Last Day to Add Classes	Thursday	February 21
Easter Holiday – Spring Break	Monday-Sunday	April 22-28
Last Day of Class	Thursday	May 16
Commencement	Friday	May 31

Academic Probation

The Administrative Committee of HIS University shall declare a student on academic probation in the following events:

1. Undergraduate student's semester GPA falls below 2.0
2. Master's student's semester GPA falls below 3.0
3. Doctoral student's semester GPA falls below 3.3

The student will be placed on Academic Probation and allowed one semester to bring their GPA to the required average. Should the student achieve the appropriate overall GPA or better, they will be removed from Academic Probation status.

Should the student be unable to achieve the required grade point average in this time span, the student will be terminated for a minimum of one semester. The terminated student may re-enroll after one semester is completed. If accepted, the student will re-enter on Academic Probation for one semester during which time they should maintain the required grade point average or better. Students will not be removed from Academic Probation until both semester and total GPA is at required levels.

A grade point average should be maintained for all semesters while enrolled. (GPA is based on a 4.0 grading scale.) Any graduate student falling below a cumulative grade average of 3.0 and any undergraduate student falling below a 2.0 grade point average in any school semester will be placed on academic probation.

Students on academic probation for two (2) consecutive semesters are considered ineligible for scholarship funds that are available for the university to designate.

Application Procedures - Submit

HIS University Application

Arrange and Attend a Personal Interview

Receive Notification of Acceptance

(BPPE) BUREAU FOR PRIVATE POSTSECONDARY EDUCATION

HIS University is a private institution, not yet accredited, provisionally approved by the State of California's Bureau for Private Postsecondary Education of offer degree programs but not yet accredited. A degree program that is unaccredited or a degree from an unaccredited institution may not be recognized for some employment positions, including, but not limited to, positions with the State of California. However, the Master's Degree in Marriage and Family Therapy (MFT) is approved by the State of California. MFT Graduates are qualified and accepted for State Licensure Exams with the California Board of Behavioral Science.

To continue to offer these degree programs, HIS University is in the process of meeting the following accreditation requirements:

1. Become institutionally accredited by an accrediting agency recognized by the United States Department of Education, with the scope of the accreditation covering at least one degree program.
2. Achieve accreditation candidacy or pre-accreditation, as defined in regulations, by July 1, 2017, and full accreditation by July 1, 2020.

If HIS University stops pursuing accreditation, it must:

- Stop all enrollment in its degree programs, and
- Provide a teach-out to finish the educational program or provide a refund.

If HIS University fails to comply with accreditation requirements by the required dates, it shall have the approval to offer degree programs automatically suspended.

Any questions a student may have regarding this catalog that have not been satisfactorily answered by the institution may be directed to the Bureau for Private Postsecondary Education at 2535 Capitol Oaks Drive, Suite 400, Sacramento, CA 95833 or P. O. Box 980818, West Sacramento, CA 95798-0818, www.bppe.ca.gov, (888) 370-7589, Fax (916) 263-1897.

As a prospective student, you are encouraged to review this catalog prior to signing an enrollment agreement. You are also encouraged to review the School Performance Fact Sheet, which must be provided to you prior to signing an enrollment agreement.

A student or any member of the public may file a complaint about this institution with the Bureau for Private Postsecondary Education by calling (888) 370-7589 or by completing a complaint form,

which can be obtained on the bureau's internet website (www.bppe.ca.gov).

His University is financially solvent institution. The institution has no pending petition in bankruptcy, is not operating as a debtor in possession, has never filed a petition including currently nor in the past five years that resulted in reorganization under Chapter 11 of the United States Bankruptcy Code (11 U.S.C. Sec. 1101 et seq.).

His University has not entered into an articulation or a transfer agreement.

Challenge Exams and Achievement Tests

HIS University does not accept credits through challenge examinations and/or achievement tests.

Grading System

Each student is graded on individual achievement. The numerical grading scale is as follows:

4.0	A	95 - 100	
3.7	A-	90 - 94	
3.3	B+	87 - 89	
3.0	B	84 - 86	
2.7	B-	80 - 83	
2.5	C+	77 - 79	(2.5 is the Minimum Passing Grade for Graduate Courses and Degrees)
2.0	C	74 - 76	(2.0 is the Minimum Passing Grade for Undergraduate Courses and Degrees)
1.7	C-	70 - 73	
1.3	D+	67 - 69	
1.0	D	63 - 66	
0.7	D-	60 - 62	
0.5	F	0 - 59	

The following grades are also used with special significance in certain programs and are not used in computing GPA:

CR	Credit*	0.00
NC	No Credit***	N/A
S	Satisfactory**	0.00
US	Unsatisfactory***	0.00
R	Research*	0.00
IP	Internship in Progress*	0.00
W	Withdrawal***	N/A
AUD	Audit***	0.00

*No grade points. Credit given.

**No grade points.

***No grade points. No credit given.

High School Diploma or Equivalent

Students who do not have a high school diploma, or a recognized equivalent, prior to accepting an enrollment agreement, the student will take and pass an independently administered examination. HIS University does not accept nor administer ATB tests. If such an exam is from another country, it must be equivalent to the US standard.

Life Experience

Life Experience credit is not available at HIS University.

Program Length

Doctoral and Master's programs are allowed 7 years for completion. The BA program is allowed 4 years for completion. AA programs are allowed 2 years for completion and certificates are allowed 1 year for completion.

Termination

The Administrative Committee of HIS University shall refuse the application of any prospective student or may revoke the registration of any continuing student if that individual:

1. is convicted of a crime for an offense substantially related to the behavioral responsibilities of a minister or counselor.
2. fails to agree to or refuses to comply with any laws set by the state to regulate ministry or counseling practices.
3. falsifies admissions documents or commits multiple plagiarism offenses.

Units/Credits Defined

HIS University uses the term “units” for course credits. In academia, these terms are often synonymous. At HIS University, ONE unit is earned for every 12.5 hours of class time. All semesters are 13 weeks with the exception of doctoral studies, which are 15 weeks. Independent Study hours may also be required at the doctoral level. (Example: 3 unit courses are attended 3 hours per week for 15 weeks; a total of 45 class hours.)

Units (Credits)Transfer

HIS University has entered into articulation or transfer agreements with a variety of colleges and universities. Please contact HIS Registrar for details. Unit (Credit) Transfers are up to the discretion of the Academic Dean's Office, which will evaluate them for comparability. Maximum units transferrable into HIS programs are as follows: Doctoral Program - 12 maximum semester units; Master's Programs - 9 maximum semester units; Bachelor's Program - 44 maximum general education semester units and the Associate of Arts - 12 maximum semester units. No units are transferable into the diploma or certificate programs. HIS University will not accept or impose a benefit exam.

HIS University provides a dual-track program for the MFT and Doctoral Programs. If the student completes a doctoral program at HIS University and enters the MFT Program, 24 pre-requisite doctoral program units are allowed to be applied toward the course requirements of the MFT Curriculum. These course transfers and the dual-track MFT program must be requested by the student when they are approved and register for the MFT Program.

NOTICE: Transferability of Units/Credits and Credentials Earned

The transferability of credits into HIS University programs is at the complete discretion of HIS University. If the student chooses to transfer credits from HIS to another institution, acceptance into that institution's program in which the student is enrolling is also at the complete discretion of the institution to which the student may seek to transfer. If credits or the degrees, diplomas, or certificates earned at HIS University are not accepted at the institution where transfer is sought, it may be required that a student repeat some or all of the coursework at that institution. For this reason, attendance at HIS University must meet a student's educational goals. This may include contacting an institution to where transfer is sought after attending HIS University to determine if the student's credits, degrees, diplomas or certificates will be accepted.

HIS University has articulation agreements with the following schools: (1) Beulah Heights Bible College in Atlanta, Georgia; (2) Midwest Theological Seminary in Wentzville, Missouri; (3) Southern California Bible College and Seminary in El Cajon, California; and (4) Shasta Bible

College and Graduate School in Redding, California. Inquiries regarding these agreements may be requested from the Office of Administration.

Visas for Students

HIS University is approved by SEVIS to issue I-20 forms, which students use to acquire an F-1 Student Visa. HIS follows the government requirements issued by Student and Exchange Visitor Information system (SEVIS).

Full details of this policy are available on request. The details of this provision are on the HIS website (www.hisuniversity.org). A printed copy of this policy is provided to all international students.

Withdrawal and Leave-of-Absence – See Student Manual for Details

The Academic Dean may grant students a Leave-of-Absence in situations deemed unavoidable. Please consult the Admissions Office for full details.

(NOTE: Students returning after one year or more lapse in their studies are required to follow course requirements and fees in the current catalog when they re-enter.)

FINANCIAL INFORMATION

Financial Aid

HIS University is not eligible for federal financial aid programs. HIS University does not participate in any government or private financial aid programs. Limited scholarships are provided for missionaries and HIS University faculty members when funds are available. Please see Registrar for details.

Financial Due Dates

Tuition and all other fees are due at enrollment or at the time incurred.

Financial - General

- Photocopying (determined each semester)
- Lost or damaged library books (replacement cost)
- Student cancelled or overdraft check fees will be charged to the students account.

Financial Loans – Important Information Regarding Student Loans

If the student obtains a loan to pay for the university's educational program, the student will have the responsibility to repay the full amount of the loan plus interest, less the amount of any refund. If the student is eligible for a loan guaranteed by the state or federal government and the student defaults on the loan, both of the following may occur:

1. The federal or state government or a loan guarantee agency may take action against the student, including applying any income tax refund to which the person is entitled to reduce the balance owed on the loan.
2. The student may not be eligible for any other federal student financial aid at another institution or other government assistance until the loan is repaid.
3. HIS University is not a participant in the Federal Student Aid (FSA) loan program at this time.

Program Tuition

DEGREE FOCUS 학위및전공	Clock Hours	Total Units	Tuition Per Unit*		Total Program Cost*	
			Local	F1	Local	F1
Ph.D. in Family Ministry 가정사역전공 철학박사	750	60	\$650	\$800	\$39,000	\$48,000
Ed.D. in Christian Education and Counseling 교육학상담전공 교육학박사	750	60	\$650	\$800	\$39,000	\$48,000
MA in Marriage and Family Therapy 결혼가족치료학석사	838	67	\$600	\$750	\$40,200	\$46,900
MA in Christian Counseling 기독교상담학석사	600	48	\$450	\$550	\$21,600	\$26,400
MA in Christian Education 기독교교육학석사	600	48	\$450	\$550	\$21,600	\$26,400
Bachelor of Arts in Counseling 상담학학사	750	60	\$400	\$500	\$24,000	\$30,000
Associate Degree in Counseling 전문대상담학사****	750	60	\$400	\$500	\$24,000	\$30,000
DIPLOMA FOCUS 디플로마 전공	Clock Hours	Total Units	Tuition Per Unit*		Total Program Cost*	Fulltime Per Semester Cost*
Peer Counseling Diploma 상담자 디플로마			Local	F1		
	300	24	\$400	\$500	\$9,600	\$12,000

*School funds are accepted in US Currency only.

School Fees

Application Fee (non-refundable)	\$ 200.00
Registration Fee (each semester; non-refundable)	\$ 25.00
Late Registration Fee (each semester; non-refundable)	\$ 25.00
Student Counsel Fee (once per degree)	\$ 100.00
Library Fee (each semester; non-refundable)	\$ 10.00
Transfer Unit Fee (each unit)	\$ 25.00
Degree Change/Upgrade Fee: Determined by degree	\$ 100.00
Graduation Fee – Diploma and Certificates	\$ 400.00
Graduation Fee – Associate and Bachelor's Degree	\$ 400.00
Graduation Fee – Master's Degree	\$ 600.00
Graduation Fee – Doctoral Degree	\$ 800.00
Doctoral Comprehensive Exam Fee	\$ 600.00
Doctoral Dissertation or Project Fee	\$1,000.00
Doctoral Continuation Fee (per semester)	\$2,000.00
International Student I-20	\$ 500.00
Matriculation Fee	\$ 100.00
Add or Drop (each request)	\$ 5.00
Transcript Copy Fee	\$ 5.00
Degree Replacement Fee	\$ 25.00
Reinstatement Fee (after one semester absence)	\$ 100.00
STRF Fee (if applicable; non-refundable)*	
Counseling Practicum Fee**	

Resident Housing and Tutoring***
 Textbook Fees, Learning Labs and Media Fees (each semester)****

*All newly enrolled California residents will be assessed a STRF fee of \$.00 per \$1,000 charged for their program upon enrollment as required by California statute.
 **This fee is determined by and paid directly to the Therapist or Agency where the student does their practicum.
 ***HIS University does not offer housing. Tutoring is not provided by the school however, tutors hired by students are allowed to sit in their classes at no charge.
 ****These fees vary with each student’s course choices. This total will be determined for each student, each semester and included in the total charges included in the Enrollment Agreement.

Refund Policy: Programs and Courses

HIS University only offers face-to-face education. The student may withdraw from a course after instruction has started and receive a pro-rated refund for the unused portion of the tuition and other refundable charges if you have completed 60% or less of the instruction. The refund will be based on tuition paid and costs derived from the HIS Catalogue or the student entry year. The refund will be calculated as outlined by the State Educational Code. Tuition paid by a third party will be refunded to that party as described above. If HIS University cancels or discontinues a course or educational program, the school will make a full refund of all charges unless a course or comparable program is substituted. If student has received federal student aid funds, the student is entitled to a refund of moneys not paid from federal student financial aid program funds. Refunds will be paid within 30 days of cancellation or withdrawal and require written notification.

The student has the ability to cancel without financial obligation other than non-refundable fees, not to exceed \$250, no later than the first class of the of the semester. The students who choose to cancel enrollment should notify the school’s administrative officer by written notice via mail. The remaining tuition, (tuition charges remaining after subtracting the non-refundable fees already retained) will be refunded based on the course completion ratio and the tuition percentage listed below.

Students who withdraws during the:			
13 Week Course	Receive	15 Week Course	Receive
1st week	100%	1st week	100%
2nd, 3rd and 4th weeks	75%	2nd, 3rd, 4th and 5th weeks	75%
5th, 6th, and 7th weeks	50%	6th, 7th and 8th weeks	50%
8th week	25%	9th week	25%

Right to Cancel

Student withdrawal may be effectuated by the student’s written notice or by the student’s conduct, including, but not necessarily limited to, a student’s lack of attendance. The student has the right to cancel the enrollment and obtain a refund.

If written notice of cancellation is made prior to or on the first day of instruction or the seventh day after enrollment, whichever is later, the institution shall refund all charges, less the deposit or application fee not to exceed one hundred dollars (\$100).

Cancellation shall occur when the student gives dated, written notice of cancellation at the address of HIS University shown on the cover of this catalog. The written notice of cancellation, if sent by mail, is effective when deposited in the mail properly addressed with postage prepaid and need not take any particular form. Refunds are paid within 30 days from receipt of written notice.

Cancellation initiated by HIS University that occurs because of a student's conduct, including, but not necessarily limited to, a student's lack of attendance, shall occur when the institution gives dated, written notice and reason for cancellation directly to the student. If sent by mail to the address provided at enrollment, the cancellation is effective when deposited in the mail properly addressed with postage prepaid and need not take any particular form.

STRF – Student Tuition Recovery Fund

The Student Tuition Recovery Fund (STRF) was established by the Legislature to protect any California resident who attends a private postsecondary institution from losing money if he/she prepaid tuition and suffered a financial loss as a result of the school's closing, failing to live up to its enrollment agreement, or refusing to pay a court judgment.

You must pay the state-imposed assessment for the Student Tuition Recovery Fund (STRF) if all of the following applies to you:

1. You are a student in an educational program, who is a California resident, or are enrolled in a residency program, and prepay all or part of your tuition either by cash, guaranteed student loans, or personal loans, and
2. Your total charges are not paid by any third-party payer such as an employer, government program or other payer unless you have a separate agreement to repay the third party. You are not eligible for protection from the STRF and you are not required to pay the STRF assessment if either of the following applies:
 - A. You are not a California resident, or are not enrolled in a residency program, or
 - B. Your total charges are paid by a third party, such as an employer government program or other payer, and you have no separate agreement to repay the third party.

The State of California created the Student Tuition Recovery Fund (STRF) to relieve or mitigate economic losses suffered by students in educational programs who are California residents, or are enrolled in a residency program attending certain schools regulated by the Bureau for Private Postsecondary and Vocational Education.

You may be eligible for STRF if you are a California resident or are enrolled in a residency program, prepaid tuition, paid the STRF assessment, and suffered an economic loss as a result of any of the following:

- The school closed before the course of instruction was completed.
- The school's failure to pay refunds or charges on behalf of a student to a third party for license fees or any other purpose, or to provide equipment or materials for which a charge was collected within 180 days before the closure of the school.
- The school's failure to pay or reimburse loan proceeds under a federally guaranteed student loan program as required by law or to pay or reimburse proceeds received by the school prior to closure in excess of tuition and other costs.
- There was a material failure to comply with the Act or this Division within 30 days before the school closed or, if the material failure began earlier than 30 days prior to closure, the period determined by the Bureau.
- An inability after diligent efforts to prosecute, prove, and collect on a judgment against the institution for a violation of the Act.

It is important that copies are kept of the enrollment agreement, receipts, or any other information that documents the monies paid to the school. Questions regarding the STRF may be directed to the Bureau for Private Postsecondary and Vocational Education, 400 R Street, Suite 5000, Sacramento, CA95814-6200, (916)445-3427.

GENERAL INFORMATION

Accreditation Status

HIS University is a private institution approved to operate by the California Bureau for Private Postsecondary Education. Approval to operate means the institution is compliant with the minimum standards contained in the California Private Postsecondary Education Act of 2009 (as amended) and Division 7.5 of Title 5 of the California Code of Regulations at this time.

Please note that state licensure is not accreditation. HIS University is engaged in the process of qualifying for accreditation with Transnational Association of Christian Colleges and Schools (TRACS). HIS University does not yet hold accreditation and does not give federal loans. The estimated time for acquiring accreditation is 2020.

Changes in the Catalog

HIS University reserves the right to revise information in the catalog as necessary, including changes in curriculum, personnel, procedures, policies, and fees. HIS is subject to all changes requested by the State of California as represented by the Bureau for Private Postsecondary Education (BPPE) or by the Federal Government. Changes will be noted as catalog addendums on the HIS website if they occur before the publishing of the next year's new catalog.

Community Agreement – See Student Manual for Details

HIS University values maintaining certain behavior standards that contribute to the atmosphere on campus, fosters fellowship with a wide range of Christians, and, in many instances, assists in strengthening our Christian testimony to our community. Hence, HIS University asks its students and employees to be supportive of this behavioral standard. HIS reserves the right to dismiss a student or staff member who, in its judgment, does not conform either to the stated regulations governing student and staff conduct or to the expressed principles, policies, and programs of the university.

Education Site

All classes and sessions will be held within school grounds in 1245 West 6th Street Corona, CA 92882. Special activities, which require other locations, will be noted 2-3 weeks prior to each session.

Facilities and Equipment

School building access is open at various hours. Please check with the office for current schedules. School equipment may not be removed or used without permission from the COO.

Grievance Procedure – See Student Manual for Details

At times, differences in interpretation of school policies occur among students, faculty, and/or administrative staff. When this happens, we urge all involved parties to communicate any problems directly to the individual(s) involved. Normally miscommunication and misunderstanding can be cleared during such "discussions" and the problem resolved. If necessary, the appropriate Departmental Director should be contacted for assistance. If an understanding is unable to be reached, Student Grievance Review Request forms are available at the Reception Office. Once completed and turned into the Departmental Director, it will be presented to the Administrative Committee (ADCOM) for review. Their final decision will be provided to the student.

HIS University Faith and Practice Statement

We believe in God the Father who sent His son, Jesus the Christ, to die for our sins so that we might have eternal life in Him. Jesus rose from the dead that we, who believe in Him, may also rise. We believe that Jesus will return. We believe that the Holy Spirit has been sent to the believer as a guarantor and teacher in the believer's new and eternal life. See theologically detailed Faith Statement at the end of this catalog.

HIS University - Moral Commitment to Ethical Values and Standards

Faculty, staff, and students of HIS University are expected to embody Biblical, Christian principles in their lives and actions, and so exercise discernment in all areas of life and conduct.

Ephesians 2:10

*For we are God's workmanship, created in Christ Jesus to do good works,
which God prepared in advance for us to do.*

HIS University endeavors to achieve excellence and dedication to ethics in teaching, ministry, and service. The purpose of this statement is to provide general guidelines for strengthening the integrity of the university. These Christian principles have been implemented to enable the university to accomplish its mission and serve the public interest in an ethical way.

His University's statement identifies the basic process for integrating Christian principles into the institution's culture. HIS University expects the administration, the faculty, the staff and the students to exemplify these principles in their words, actions and professional practices.

To guide the conduct of the university community, HIS University endorses the following principles:

- **Honesty**
Members of the university community will be guided in all their activities by a high regard for truth and Christian values.
- **Respect**
Members of the university community will show concern for the individuality of others, their ideas, and contributions to the spiritual environment and academic programs.
- **Justice**
Members of the university community will treat others fairly and in accordance with Biblical commands to love one another and to serve others.
- **Accountability**
Members of the university community will be responsible stewards of the public trust.

Housing

HIS University does not provide housing for students. All students are commuters. Residential and apartment housing are available near the campus. Apartments with one to two bedrooms are available within walking distance to the school. An average of \$1200 to \$1600 monthly rent is usually required with one to three month's rent pre-deposit for apartments. Also, various single-room housing options are available. A monthly fee of \$900-\$1200 is required with breakfast and dinner included. A monthly fee of \$600-\$700 is required without meals. Some housing locations require proof of enrollment for student discounts. More detailed information concerning housing may be requested from Student Services.

Library

HIS University has both an English and a Korean library on campus. There are library agreements for shared usage with BIOLA University. Please request further details from the HIS office during regular hours.

- **HIS Library:** The library is open during school hours.
- **Biola Library:** HIS University Students may use their Student ID cards to check out books and use the BIOLA Library facility located on the BIOLA campus. Refer to the BIOLA University Website (www.library.biola.edu) for more information.

Non-Discrimination Policy

HIS University does not discriminate based on race, color, national origin, gender or religion in administration of its policies and programs.

Placement/ Out-reach Services

The following agencies offer placement service in assistance to HIS University to students and graduates alike.

1. HIS University affiliated counseling center: HOME International
951-372-8080 ext. 105, 106
1245 W. 6th Street
Corona, CA 92882

2. Korean Community Services
7212 Orangethorpe Ave. Suite 8,
Buena Park, CA 90621
&
1050 S. Brookhurst Rd.
Fullerton, CA 92822
www.koreancommunity.org

3. Outreach Concern
400 N. Tustin Ave. #360
Santa Ana, CA 92705
714-319-7638

4. Hanmi Family Counseling Center
11501 Brookhurst St. #201
Garden Grove, CA 92840
714-590-0017

5. Asian and Pacific Islander Mental Health Alliance
605 W. Olympic Blvd. Suite 600
Los Angeles, CA 92833
213-445-6966

Plagiarism

Plagiarism is both unacceptable and inexcusable. The Academic Dean will determine the appropriate action for any such offense.

Student Code of Conduct

A student may be failed or dismissed for academic dishonesty, or acts or inattention that violate professional ethics in patient care. At the discretion of the Academics Dean and Administrative Committee, a student may be dismissed from the university for behavior disruptive to the educational mission of the university, such as, but not limited to, those stated below:

- * Cheating, bribery, or plagiarism in connection with an academic program;
- * Forgery, alteration or misuse of university documents, records or identification, or knowingly furnishing false information to the university.
- * Misrepresentation of oneself or an organization to be an agent of the university;
- * Obstruction or disruption on or off-campus property, of the campus educational process administrative process, or other campus function;
- * Physical abuse, on or off campus property, of the person or property of any member of the campus community, or members of this/her family or the threat of such physical abuse;
- * Theft of or non-accidental damage to university property or property in the possession of or owned by a member of the university community;
- * Unauthorized entry into, unauthorized use, or misuse of university property;
- * Sale or knowing possession of dangerous drugs, restricted drugs, or narcotics, as those terms are used in California statutes, except when lawfully prescribed pursuant to medical or dental care, or when lawfully permitted for the purpose of research, instruction or analysis;
- * Lewd, indecent, or obscene behavior on university property or at a university function;
- * Abusive behavior directed toward a member of the university community;
- * Violation of any order of the university President, notice of which has been given prior to such violation and during the academic term in which the violation occurs, either by publication or by posting on an

official bulletin board designed for this purpose, and which order is not inconsistent with any of the other provision of this section;

* Soliciting or assisting another to do any act that would subject a student to dismissal, suspension, or probation pursuant to this section.

The President of HIS University, at his/her discretion and prior to recommendations or actions of the Administrative Committee, in the interests of the university may place on probation, suspend or dismiss a student for one or more of the causes enumerated above. Any adjustment of fees or tuition shall be those required by law.

Student Records

Student Records policy is based on current requirements of the California Private Postsecondary Education Act of 2009 (section 94900). HIS University maintains the name, address, e-mail address, and telephone number of each student who is enrolled in its' educational program. HIS University maintains for each student granted a degree, diploma or certificate, permanent records of the following:

- 1) The degree, diploma and/or certificate granted and the date earned.
- 2) The courses and units on which the degree, diploma or certificate was based.
- 3) The grades earned by the student on each course taken.
- 4) Academic files and financial records are maintained separately for a period of five years after their graduation date or date of withdrawal.

The university's policy is to maintain the confidentiality of student academic records. No one outside of the institution shall have access to, nor will the university disclose, any information from a student's academic records without the written consent of the student except:

- School officials with legitimate educational interest;
- Other schools to which a student is transferring, specified officials for audit or evaluation purposes;
- Appropriate parties in connection with financial aid to a student;
- Organizations conducting certain studies for or on behalf of the school;
- Accrediting organizations;
- To comply with a judicial order or lawfully issued subpoena; and
- Appropriate officials in cases of health and safety emergencies.

The student's academic file is the sole property of HIS University. The university will not release copies of documents of course work from other institutions attended. Further information is provided online at <http://studentprivacy.ed.gov/> or in the FERPA bulletin handout, family educational rights and privacy policies of HIS University which are available in the Reception Office. Students who believe that academic records contain inaccurate or misleading information may discuss their concerns informally with the Registrar. If the decisions are in agreement with the student's request, the records will be amended. If not, the student may follow additional procedures outlined in the privacy policies bulletin (FERPA) noted above.

Student Services

A Student Council assists in communication between the general student body and HIS University.

The HIS University Administration Office personnel provide personal assistance to students as needed. If necessary, referrals are made to appropriate HIS University staff.

Transcripts and Records

ALL financial obligations to HIS University must be met before any transcript, diploma or certification is issued. Transcript requests must be submitted in writing, dated, signed and paid for by the student. Verbal requests for transcripts are not accepted.

Withdrawal Grades

- A "W" indicates an official withdrawal from a course. The student's grade at the time is not averaged into the student's grade average.

- A “LW” indicates a late withdrawal. Students who withdraw after the deadline for dropping a course will receive a “LW” grade (LWA, LWA-, LWA+, LWB+, etc.). This will influence the grade average the same as an official grade.
- Students who register for a class but do not attend it automatically receive an Unauthorized Withdrawal grade of “UWF” which will receive a course grade as an “F”.

ACADEMIC PROGRAMS

DOCTOR OF PHILOSOPHY

Family Ministry

Program Description

The Doctor of Philosophy degree in Family Ministry is designed to equip highly competent professionals to conduct research, publish and teach. The degree emphasizes family ministry components of education and places a strong emphasis on family ministry leaders’ training.

Formatted: Font: Bold, Underline

Mission Statement and Course Objectives

The preventive and healing ministry for family is an urgent mission for the whole world; every country, community, churches and mission organization. Every professional leader will be able to be a family ministry leader through the educational training of HIS University Doctor of Philosophy in Family Ministry. The professors of universities and colleges, school teachers, medical doctors, artists, business men and women, housewives and church leaders should know how to research, teach, write, and/or train others for effective family ministry at home, churches, communities, and other organizations.

Graduation Requirements

A student must complete 60 units of the required Ph.D. program curriculum to be eligible for graduation. (A maximum of 12 transfer units is allowed.) Prior to graduation approval, the student must also:

1. Complete the 60 required curriculum units with a GPA of 3.3 in all coursework.
2. Complete all units within a seven (7) year time span from date of entry.
3. Complete a comprehensive exam.
4. Pay all outstanding financial requirements including tuition and fees.
5. File an application for intent to graduate with the school office 6 weeks prior to graduation to certify that all graduation requirements have been met.
6. Orally defend and submit an approved dissertation.
7. Submit the required copies of the bilingual dissertation.

Core Program Requirements (60 Semester Units 60 학점)

DFM700 Family Education and Counseling Research 가정교육과상담 (4)
 DFM710 Biblical Studies on Family Ministry 성경적가정사역 (4)
 DFM720 Advanced Pastoral Counseling 고급목회상담 (4)
 DFM730 Family Ministry Program Development 가정사역프로그램개발 (4)
 DFM731 Team Ministry Research 팀사역연구 (4)
 DFM744 Special Topics in Family Studies 가정특수문제 (4)
 DFM750 Research Design 연구디자인 (4)
 DFM780 Advanced Field Experience I 고급현장실습 I (4)
 DFM781 Advanced Field Experience II 고급현장실습 II (4)
 DFM790 Dissertation 논문 (8)
 DFM792 Ph.D. Continuous Enrollment 논문학기 (0)

Electives 선택 (16)

TOTAL UNITS FOR GRADUATION(총학점 60 Units 60 학점)

NOTE: Applicant must have completed at least three years of full-time ministry experience with evidence of leadership gifts and abilities and the following 24 units of prerequisite course requirements:

Cross-cultural Education and Family Ministry 초문화교육과가정사역 (3)

Interpersonal and Intercultural Relationship 대인및대문화관계훈련 (3)

Christian Marriage and Family Counseling 결혼과가정상담 (3)

Christian Counseling and Psychotherapy 기독교상담과심리치료 (3)

Family Therapy 가족치료 (3)

Group Counseling 그룹상담 (3)

Marital Counseling 부부상담(3)

Research Methods 조사방법 (3)

Notice to Prospective Degree Program Students

This institution is provisionally approved by the Bureau for Private Postsecondary Education to offer degree programs. To continue to offer this degree program, this institution must meet the following requirements:

- Become institutionally accredited by an accrediting agency recognized by the United States Department of Education, with the scope of the accreditation covering at least one degree program.
- Achieve accreditation candidacy or pre-accreditation, as defined in regulations, by September 1, 2017, and full accreditation by July, 2020.
- Stop all enrollment in its degree programs, and
- Provide a teach-out to finish the educational program or provide a refund.

An institution that fails to comply with accreditation requirements by the required dates shall have its approval to offer degree programs automatically suspended.

DOCTOR OF EDUCATION Christian Education and Counseling

Program Description

The primary goal of the Doctor of Education degree is to train students to be effective professionals who can structure and develop Christian educational and family counseling ministries within Christian organizations in support of the local church.

Mission Statement and Course Objectives

The mission statement of Doctor of Education in counseling is to be Christian leaders majoring in counseling in order to train lay counselors in the local churches, schools, communities and mission fields to help individuals, couples, families and children with their mental health. The graduates will have vision and tools to build helping communities to develop "healthy families" where every member will trust, support and empower each other.

Graduation Requirements

A student must complete 60 units of the required Ed.D. Program curriculum to be eligible for graduation. (A maximum of 12 transfer units is allowed.) Prior to graduation approval, the student must also:

1. Complete the 60 required curriculum units with a GPA of 3.3 in all coursework.
2. Complete all units within a seven (7) year time span from date of entry.
3. Complete a comprehensive exam.
4. Pay all outstanding financial requirements including tuition and fees.

5. File an application for intent to graduate with the school office 6 weeks prior to graduation to certify that
6. All graduation requirements have been met.
7. Orally defend and submit an approved dissertation
8. Submit the required copies of the bilingual dissertation.

Specific Semester Units required for the Doctor of Education in Christian Education and Counseling: 60

Core Program Requirements (60 Semester Units 60 학점)

- EDD701 Family Education and Counseling Research 가정교육과상담연구 (4)
- EDD702 Special Topics in Family Studies 주제별가정연구 (4)
- EDD703 Advanced Child and Adolescent Counseling 고급 아동과 청소년 상담 (4)
- EDD704 Counselor Training Program Development 상담자훈련 프로그램개발 (4)
- EDD705 Supervision Skills for Counselors 슈퍼비전 기술훈련 (4)
- EDD710 Advanced Adult and Senior Education and Counseling 고급성인, 노인교육과상담 (4)
- EDD720 Advanced Abnormal Psychology 고급이상심리학 (3)
- EDD721 Alcoholism and Substance Abuse 알코올과약물중독 (1)
- EDD722 Domestic Violence Workshop 가정폭력워크샵 (1)
- EDD723 Child Abuse Workshop 아동학대워크샵 (1)
- EDD730 Research Design 연구디자인 (4)
- EDD780 Advanced Field Practicum 고급현장실습 I (4)
- EDD781 Advanced Field Practicum 고급현장실습 II (4)
- EDD790 Dissertation 논문 (8)
- EDD792 Ed.D. Continuous Enrollment 논문학기 (0)
- Electives 선택 (10)

TOTAL UNITS FOR GRADUATION(총학점 60 Units 60 학점)

NOTE: The applicant must have complete the following 24 units of prerequisite course requirements:

- Cross-cultural Education and Family Ministry 초문화교육과가정사역 (3)
- Interpersonal and Intercultural Relationships 대인및대문화관계훈련 (3)
- Legal, Ethical and Moral Issues in Therapy 치료의윤리와법 (3)
- Christian Marriage and Family Counseling 결혼과가정상담 (3)
- Christian Counseling and Psychotherapy 기독교상담과심리치료 (3)
- Family Therapy 가족치료 (3)
- Group Counseling 그룹상담 (3)
- Marital Counseling 부부상담(3)

Notice to Prospective Degree Program Students

This institution is provisionally approved by the Bureau for Private Postsecondary Education to offer degree programs. To continue to offer this degree program, this institution must meet the following requirements:

- Become institutionally accredited by an accrediting agency recognized by the United States Department of Education, with the scope of the accreditation covering at least one degree program.
- Achieve accreditation candidacy or pre-accreditation, as defined in regulations, by September 1, 2017, and full accreditation by July, 2020.
- Stop all enrollment in its degree programs, and
- Provide a teach-out to finish the educational program or provide a refund.

An institution that fails to comply with accreditation requirements by the required dates shall have its approval to offer degree programs automatically suspended.

MASTER OF ARTS

Marriage and Family Therapy

Program Description

The primary goal of the M.A. in Marriage and Family Therapy is to prepare individuals who wish to develop a sound foundation in the theoretical and applied practice of professional counseling with individuals, couples and families. The program will prepare students to obtain licensure and practice in California as Marriage and Family Counselors.

Mission Statement and Course Objectives

The objective of this degree is to equip students with theoretical and practical training that qualifies them to become Licensed Marriage and Family Therapists. Students are trained to become professional therapists capable of counseling individuals, couples, families, and children. Graduates are registered with the Board of Behavioral Sciences (BBS) to become Associate Marriage and Family Therapists under the guidance of Approved and Certified Supervisors.

Graduation Requirements

A student must complete 67 units of the required MFT Program curriculum to be eligible for graduation. (A maximum of 12 transfer units is allowed.) Prior to graduation approval, the student must also:

1. Complete the 67 required curriculum units with a minimum GPA of 2.0 in all coursework.
2. Complete all units within a seven (7) year time span from date of entry.
3. Pay all outstanding financial requirements including tuition, school, and counseling fees,
4. File an application for intent to graduate with the school office 6 weeks prior to graduation to certify that all graduation requirements have been met,
5. Graduates must fulfill MFT Policy Language Requirements: TOEFL Score PBT550 or IBT 80 above and Equivalent (MFT Degree Only).

Specific semester units required for the Master of Arts in Marriage and Family Therapy Studies: 67 Semester Units.

Foundational Courses (16 Semester Units 16 학점)

MFT500 Research Methods 조사방법 (1)
MFT510 Cross-Cultural Education and Family 초문화교육과과정 (3)
MFT511 Interpersonal and Intercultural Relationships 대인및대문화관계론 (3)
MFT514 Marriage and Family Counseling 결혼과과정상담 (3)
MFT544 Special Topics in Psychotherapy 특별주제심리치료 (3)
MFT551 Theories of Personality and Psychotherapy 성격이론과심리치료 (3)

Professional Course Work (34 Semester Units 34 학점)

MFT512 Legal, Ethical and Moral Issues in Therapy 치료의윤리와법 (3)
MFT513 Group Counseling 그룹상담 (3)
MFT540 Child Abuse Workshop 아동학대웍샵 (1)
MFT541 Domestic Violence Workshop 가정폭력웍샵 (1)
MFT542 Psychopharmacology 정신약리학 (2)
MFT543 Aging and Long –Term Care 노인학 (1)
MFT544 Special Topics in Psychotherapy 특별주제심리치료 (1)
MFT552 Human Sexuality and Sex Therapy 성과성치료 (2)
MFT557 Marital Therapy 부부치료 (3)
MFT561 Child and Adolescent Therapy 아동및청소년치료 (3)
MFT563 Recovery Model of Mental Illness (Psychopathology) 정신병리학 (3)
MFT564 Severe Mental Illness 중증 정신질환 (3)
MFT571 Family Therapy 가족치료 (3)

MFT577 Psychological Assessment Skills and Test 심리평가 (3)
MFT580 Introduction to Clinical Practice: Basic Skills 기초임상실습 (2)
MFT581 Introduction to Clinical Practice: Advanced Skills 고급임상실습 (3)
MFT596 Crisis Counseling 위기상담 (3)
MFT595 Alcoholism and Substance Abuse 알코올과약물중독 (3)
Electives 선택 (3)

NOTE: 12 Semester Units, including MFT512 Legal, Ethical, and Moral Issues in Therapy, must be taken before Clinical Placement I.

Practicum Course Work (6 Semester Units 6 학점)

MFT597 Clinical Placement I 임상실습 I (3)
MFT598 Clinical Placement II 임상실습 II (3)

TOTAL UNITS FOR GRADUATION(총학점 67 Units 67 학점)

Prerequisites

The following two prerequisite course requirements must be taken within 2 years of entering this MFT Program of Study:

1. Abnormal Psychology 이상심리학 (3)
2. Human Growth and Development 인간발달(3)

Practicum Hours

Complete 250 hours of supervised, direct, in-person contact counseling which includes 75 hours of Client Centered Advocacy (CCA).

The following two prerequisite course requirements must be taken prior to entering Clinical Placement I:

1. Introduction to MFT580 Clinical Practice: Basic Skills 기초임상실습 (3)
2. Introduction to MFT581 Clinical Practice II: Advanced Skills 고급임상실습 (3)

Abnormal Psychology Presentation

Candidates for graduation are required to present a 6-hour presentation on a pre-approved topic related to Abnormal Psychology and schedule this presentation through the Counseling Program Director.

Notice to Prospective Degree Program Students

This institution is provisionally approved by the Bureau for Private Postsecondary Education to offer degree programs. To continue to offer this degree program, this institution must meet the following requirements:

- Become institutionally accredited by an accrediting agency recognized by the United States Department of Education, with the scope of the accreditation covering at least one degree program.
- Achieve accreditation candidacy or pre-accreditation, as defined in regulations, by September 1, 2017, and full accreditation by July, 2020.
- Stop all enrollment in its degree programs, and
- Provide a teach-out to finish the educational program or provide a refund.

An institution that fails to comply with accreditation requirements by the required dates shall have its approval to offer degree programs automatically suspended.

MASTER OF ARTS Christian Counseling

Program Description

The primary goal of the M.A. in Christian Counseling is to train students to be effective counselors integrating Christian faith and psychology.

Mission Statement and Course Objectives

The mission statement of MA in Christian Counseling is to become trustworthy and effective Christian counselors with holistic perspectives; physically, spiritually, socially and mentally. The students will learn how to help individuals and families integrating psychological theories and Biblical knowledge in the local churches and other mission organization.

Graduation Requirements

A student must complete 48 semester units to eligible for graduation. (A maximum of 9 transfer units is allowed.) Generally, the student must complete the following:

1. Complete 48 semester units with a minimum GPA of 2.0 in all coursework.
2. Complete all units within a seven (7) year time span from date of entry.
3. Complete a comprehensive exam or an additional 12 semester units as approved by the Academic Dean.
4. Complete all financial requirements.
5. File an application for intent to graduate with the school office 6 weeks prior to graduation to certify that all graduation requirements have been met.
6. Specific semester units required for the Master of Arts in Christian Counseling Studies: 48 Semester Units

Core Program Requirements (48 Semester Units 48 학점)

MCC500 Research Methods 조사방법 (3)
MCC510 Cross-Cultural Education and Family Ministry 초문화교육과가정사역 (3)
MCC511 Interpersonal and Intercultural Relationships 대인관계문화관계훈련 (3)
MCC514 Christian Marriage and Family Counseling 결혼과가정상담 (3)
MCC518 Human Growth and Development 인간발달 (3)
MCC545 Family Therapy 가족치료 (3)
MCC555 Child and Youth Counseling 아동과청소년상담 (3)
MCC560 Christian Counseling and Psychotherapy 기독교상담과심리치료 (3)
MCC563 Theories of Psychotherapy 심리치료이론 (3)
MCC564 Abnormal Psychology 이상심리학 (3)
MCC565 Group Counseling 그룹상담 (3)
MCC570 Practicum I 실습 I (3)
MCC571 Practicum II 실습 II (3)
Electives 선택 (9)

TOTAL UNITS FOR GRADUATION(총학점 48 Units 48 학점)

Notice to Prospective Degree Program Students

This institution is provisionally approved by the Bureau for Private Postsecondary Education to offer degree programs. To continue to offer this degree program, this institution must meet the following requirements:

- Become institutionally accredited by an accrediting agency recognized by the United States Department of Education, with the scope of the accreditation covering at least one degree program.
- Achieve accreditation candidacy or pre-accreditation, as defined in regulations, by September 1, 2017, and full accreditation by July, 2020.
- Stop all enrollment in its degree programs, and
- Provide a teach-out to finish the educational program or provide a refund.

An institution that fails to comply with accreditation requirements by the required dates shall have its approval to offer degree programs automatically suspended.

**MASTER OF ARTS
Christian Education**

Program Description

The primary goal of the M.A. in Christian Education is to provide the student with education that combines Christian faith with contemporary knowledge of development of health family living.

Mission Statement and Course Objectives

MA in Christian Education aims to train professional Christian teachers who are well-balanced in character, knowledge and skills with warm heart and intelligence in local churches, Christian schools, and other mission organizations.

Graduation Requirements

A student must complete 48 semester units to eligible for graduation. (A maximum of 9 transfer units is allowed.) Generally, the student must complete the following:

1. Complete 48 semester units with a minimum GPA of 2.0 in all coursework.
2. Complete all units within a seven (7) year time span from date of entry.
3. Complete a comprehensive exam or an additional 12 semester units as approved by the Academic Dean.
4. Complete all financial requirements.
5. File an application for intent to graduate with the school office 6 weeks prior to graduation to certify that all graduation requirements have been met.
6. Specific Semester Units required for the Master of Arts in Christian Education Studies: 48 Semester Units

Core Program Requirements (48 Semester Units 48 학점)

MCE500 Research Methods 조사방법 (3)
MCE501 Introduction to Christian Education 기독교교육개론 (3)
MCE510 Cross-Cultural Education and Family Ministry 초문화교육과가정사역 (3)
MCE511 Interpersonal and Intercultural Relationships 대인및대문화관계론 (3)
MCE513 Child and Youth Education 아동과청소년교육 (3)
MCE514 Christian Marriage and Family Education 결혼과가정교육 (3)
MCE515 Adult and Senior Education 성인과노인교육 (3)
MCE518 Human Growth and Development 인간발달 (3)
MCE520 Parenting Education 부모교육 (3)
MCE534 Special Topics in Education I 특별주제교육 I (3)
MCE535 Special Topics in Education II 특별주제교육 II (3)
MCE570 Field Education I 현장교육 I (3)
MCE571 Field Education II 현장교육 II (3)
Electives 선택 (9)

TOTAL UNITS FOR GRADUATION(총학점 48 Units 48 학점)

Notice to Prospective Degree Program Students

This institution is provisionally approved by the Bureau for Private Postsecondary Education to offer degree programs. To continue to offer this degree program, this institution must meet the following requirements:

- Become institutionally accredited by an accrediting agency recognized by the United States Department of Education, with the scope of the accreditation covering at least one degree program.
- Achieve accreditation candidacy or pre-accreditation, as defined in regulations, by September 1, 2017, and full accreditation by July, 2020.
- Stop all enrollment in its degree programs, and
- Provide a teach-out to finish the educational program or provide a refund.

An institution that fails to comply with accreditation requirements by the required dates shall have its approval to offer degree programs automatically suspended.

BACHELOR OF ARTS Counseling

Program Description

The Counseling major provides opportunities to study a broad spectrum of issues concerning human nature and functioning from a distinctly Christian worldview. Because Christian Counseling is selected as major for various reasons, the curriculum is designed to provide as much flexibility as possible. Students preparing for graduate study in counseling should take a broad set of courses in the research and theory of counseling. All baccalaureate degrees at HIS University require completion of the requirements listed below. Degree requirements fall into three categories: general education requirement, major/minor requirements; and other all-university requirements.

Mission Statement and Course Objectives

The objective of the BA in Counseling program is to train students to have basic character and knowledge as Christian counselors with a Biblical worldview. The graduates will be able to help themselves and their acquaintances to overcome issues and/or crisis in individuals, families, church and other communities. The graduates will have knowledge and standards to equip themselves to become professional counselors.

Graduation Requirements

A student must complete 120 semester units to be eligible for graduation. Generally, the student must complete the following:

1. Complete 120 semester units with a GPA of 2.0 in all coursework. A maximum of 80 transfer units is allowed. (Quarter units may be converted to semester units by multiplying by two-thirds.)
2. Complete all units within a four (4) year time span from date of entry.
3. Complete all financial requirements.
4. File an application for intent to graduate with the school office 6 weeks prior to graduation to certify that all graduation requirements have been met.

** Total units required for graduation*

A minimum of 120 units is required. No more than 80 units taken at a community college or other two-year college may be applied to this total, excluding military credit and credit by examination, which are not included in this limit. Quarter units may be converted to semester units by multiplying by two thirds.

** Upper Division units required for graduation*

Completion of at least 40 of the total units must be upper division. HIS University *lower division courses* are numbered 100-199; *upper division courses* are numbered 200-299. (Major requirements must include a minimum of 24 upper division units for a Bachelor of Arts degree; therefore, at least 24 of 40 will automatically be completed upon completion of the major. The remainder may be in any other upper division category; i.e., minor, General Education or electives.)

Specific Semester Units required for the Bachelor of Arts in Counseling: 120 Units

Core Program Requirements – (42 Semester Units 42 학점)

BAC300 Introduction to Research Methods 기초조사방법론 (3)
BAC310 Foundations of Christian Counseling 기독교상담학 (3)
BAC311 Premarital Counseling 혼전상담 (3)
BAC312 Biblical Foundations of Marriage and Family 결혼과가정상담의성경적기초 (3)
BAC320 Introduction to Child Counseling 어린이상담입문 (3)
BAC321 Introduction to Adolescent Counseling 청소년상담입문 (3)
BAC330 Counseling Seminar 상담세미나 (3)

BAC331 Special Topics in Counseling 특별주제상담 (3)
BAC350 Introduction to Psychology 심리학입문 (3)
BAC451 Developmental Psychology 기초발달심리학 (3)
BAC452 Abnormal Psychology 이상심리학 (3)
BAC460 Human Relationship 인간관계론 (3)

BAC470 Personality Theory 성격이론 (3)
BAC480 Foundations of Psychotherapy 정신분석치료입문 (3)

Total Major Core Units (42)
Electives (19)
Biblical Studies Units (15)
Total General Education (44)

TOTAL UNITS FOR GRADUATION (총학점 120 Units 120 학점)

Notice to Prospective Degree Program Students

This institution is provisionally approved by the Bureau for Private Postsecondary Education to offer degree programs. To continue to offer this degree program, this institution must meet the following requirements:

- Become institutionally accredited by an accrediting agency recognized by the United States Department of Education, with the scope of the accreditation covering at least one degree program.
- Achieve accreditation candidacy or pre-accreditation, as defined in regulations, by September 1, 2017, and full accreditation by July, 2020.
- Stop all enrollment in its degree programs, and
- Provide a teach-out to finish the educational program or provide a refund.

An institution that fails to comply with accreditation requirements by the required dates shall have its approval to offer degree programs automatically suspended.

ASSOCIATE OF ARTS DEGREE

Counseling

Program Description

The Counseling major provides opportunities to study a broad spectrum of issues concerning human nature and behavior. Because Counseling is selected as a major for various reasons by students, the curriculum is designed to provide as much flexibility as possible. Students preparing for an associate degree in counseling should take a broad set of courses in the research and theory of counseling.

The Associate Degree in Counseling at HIS University requires completion of the requirements listed below.

Degree requirements fall into three categories: general education requirements, interdisciplinary course work/professional course work requirements; and other all university requirements.

Mission Statement and Course Objectives

AA in counseling aims the students who are interested in the field of counseling to acquire the basic understanding and information on the general human nature and counseling theories. The graduates will decide whether they will continue their career as professional counselors. The educational program supports the students understanding of themselves and empowers them to assist professional counselors.

Graduation Requirements

A student must complete 60 semester units to be eligible for graduation. Generally, the student must complete the following:

1. Complete 60 semester units with a GPA of 2.0 in all coursework. Completion of all units within a three (3) year time span from date of entry.
2. Complete all financial requirements.
3. File an application for intent to graduate with the school office 6 weeks prior to graduation to certify that all graduation requirements have been met.

General Education as Foundation Courses (18 Semester Units 교양과목 18 학점)

- AAD 211 English – Comprehension 영어독해 (2)
 AAD 212 English – Writing Skills 영작 (2)
 AAD 213 English – Interview Skills 영어 인터뷰 기술 (2)
 AAD 214 Writing – Documentation 서류작성법 (2)
 AAD 215 Math – Foundations for Research 수학- 연구의 기초 (2)
 AAD 217 Science – Biology 과학-생물 (2)
 AAD 221 History – Korea, U.S.A, and World 역사-한국사, 미국사, 세계사 (2)
 AAD 231 Computer –Library Research 컴퓨터-도서열람 (2)
 AAD 240 Physical Education 체육교육 (2)

Interdisciplinary Course Work (5 Semester Units 수련교육과정 5 학점)

- ABS 201 Biblical Integration to Counseling 성경적 통합과 상담 (3)
 ABS 202 Spirituality in Counseling 영성과 상담 (2)

Professional Course Work (25 Semester Units 전문과정 31 학점)

- AAD 251 Theories of Counseling 상담의 이론 (3)
 AAD 258 Development Psychology 발달심리 (3)
 AAD 262 Communication Skills 대화기술 (3)
 AAD 263 Introduction to Abnormal Psychology 이상심리 (3)
 AAD 264 Introduction to Human Relationships 인간관계 (3)
 AAD 265 Child and Youth Counseling 아동과 청년상담 (3)
 AAD 266 Marriage and Family Counseling 결혼과 가족상담 (3)
 AAD 271 Practicum I 실습 I (2)
 AAD 272 Practicum II 실습 II (2)

Specialized Training Electives (12 Semester units 선택과목 12 학점)

- AAD 267 Legal, Ethical and Moral Issues in Counseling 상담의 법과윤리 (3)
 AAD 268 Addiction Recovery 중독회복 (3)
 AAD 281 Play Therapy 놀이치료 (3)
 AAD 282 Special Topics in Counseling 특별주제 상담 (3)
 AAD 283 Marital Therapy 부부상담 (3)
 AAD 284 Art Therapy 미술치료 (3)
 AAD 285 Music Therapy 음악치료 (3)
 AAD 286 Parenting Education and Counseling 부모교육과 상담 (3)

TOTAL UNITS FOR GRADUATION (총학점 60 Units 60 학점)

Notice to Prospective Degree Program Students

This institution is provisionally approved by the Bureau for Private Postsecondary Education to offer degree programs. To continue to offer this degree program, this institution must meet the following requirements:

- Become institutionally accredited by an accrediting agency recognized by the United States Department of Education, with the scope of the accreditation covering at least one degree program.

- Achieve accreditation candidacy or pre-accreditation, as defined in regulations, by September 1, 2017, and full accreditation by July, 2020.
- Stop all enrollment in its degree programs, and
- Provide a teach-out to finish the educational program or provide a refund.

An institution that fails to comply with accreditation requirements by the required dates shall have its approval to offer degree programs automatically suspended.

DIPLOMA Peer Christian Counseling

Program Description

The primary purpose of the Diploma in Peer Christian Counseling is to train students for effective ministry; integrating Christian faith and counseling.

Mission Statement and Course Objectives

The mission statement of the Peer Christian Counseling Diploma program is to train every member of the local church to become peer Christian counselors. The students will learn how to assess the mental health status of their neighbors and themselves as peers (on a first aid level). They will learn how to refer the more severe cases to a professional therapist. They will be able to help prevent suicides, addictions, and harm toward others caused by mental health problems.

Graduation Requirements

In order to complete and be awarded a Diploma in Christian Counseling, the student must complete 24 semester units. (No transfer units are allowed into this program) Generally, the student must complete the following:
Specific Semester Units required for the Diploma in Christian Counseling 24 Semester Units

Core Program Requirements (15 Semester Units 15 학점)

DCC101 Basic Counseling Skills 기초상담기술 (3)
DCC103 Christian Marriage and Family Counseling 결혼과가정생활상담 (3)
DCC104 Communication Skills 대화기술훈련 (3)
DCC105 Family Therapy 가족치료 (3)
DCC180 Practicum 실습 (3)

Choose three of the following courses as an elective (9 Semester Units 9 학점)

DCC102 Basic Legal, Ethical and Moral Issues in Therapy 기본치료의윤리와법 (3)
DCC511 Interpersonal and Intercultural Relationships 대인및대문화관계훈련 (3)
DCC520 Parenting Education 부모교육 (3)
DCC533 Child and Adolescent Therapy 아동과청소년치료 (3)
DCC556 Group Counseling 집단상담 (3)
DCC560 Christian Counseling and Psychotherapy 기독교상담과심리치료 (3)
Elective 선택 (9)

TOTAL UNITS FOR GRADUATION(총학점 24 Units 24 학점)

Notice to Prospective Degree Program Students

This institution is provisionally approved by the Bureau for Private Postsecondary Education to offer degree programs. To continue to offer this degree program, this institution must meet the following requirements:

- Become institutionally accredited by an accrediting agency recognized by the United States Department of Education, with the scope of the accreditation covering at least one degree program.
- Achieve accreditation candidacy or pre-accreditation, as defined in regulations, by September 1, 2017, and full accreditation by July, 2020.
- Stop all enrollment in its degree programs, and
- Provide a teach-out to finish the educational program or provide a refund.

An institution that fails to comply with accreditation requirements by the required dates shall have its approval to offer degree programs automatically suspended.

COURSE DESCRIPTIONS

DOCTOR OF PHILOSOPHY IN FAMILY MINISTRY

DFM700 Family Education and Counseling Research (4)

This course examines methods of conducting research applicable to Ph.D. projects. The student will develop a foundational topic for Ph.D. research and will then develop a plan for research that will eventually lead to writing the Ph.D. dissertation/project.

DFM710 Biblical Studies in Family Ministry (4)

Marriage and family is established by God's design, not man's. The Bible provides the theological foundation for family ministry. This course presents biblical study and research as an indispensable guide and resource for family ministry leaders. The program covers spiritual resources and insights into a biblical understanding of the family, providing guidance on the establishment of strong families and how to deal with family crisis such as divorce and spousal abuse.

DFM720 Advanced Pastoral Counseling (4)

This course provides an overview of theoretical and Biblical approaches to Pastoral Counseling. The focus of this study is on developing counseling skills needed to assist individuals to deal with their physical, relational, spiritual, emotional and moral reality. Concentration is also on developing skills needed to facilitate individuals to take responsibility for their own lives and grow in Christian maturity and personal ministry.

DFM730 Family Ministry Program Development (4)

In today's fragmented and frenetic world, families face all kinds of pressures. Accordingly, those in family ministry need a multifaceted, well-informed sense of the Christian family's purpose and of the complex world these families inhabit. Family ministry leaders have the responsibility of designing and implementing family ministry in the local church and in the mission field. Through research and practice, this course provides knowledge, tools and insight into the development of family ministry programs. The course offers an understanding of how to plan and lead family ministry through evaluation and assessment in the context of community.

DFM731 Team Ministry Research (4)

This team building course is designed to equip leaders in the development of their relational strategies within the context of church and community. Exploration of the dynamics of effective work teams, the development, maintenance, and benefits of leadership teams in family ministry settings is provided. Content includes a focus on team assignment, strategies for team development, beneficial leadership practices, and the application of team strategies to various local and cross-cultural ministry settings.

DFM740 Special Topics: Child Abuse Workshop (1)

This workshop fulfills the Board of Behavioral Sciences 7- hour requirement for training on how to provide services to victims of child abuse. Content is examined that is related to child abuse, historical precedents and other sociological factors of child abuse and an examination of Christian faith and its response to child abuse.

DFM741 Special Topics: Alcoholism and Substance Abuse (1)

This course includes a range of specialized topics that are of interest to mental health professionals. The course provides training in providing services to those suffering from alcoholism and substance abuse. Medical and social overviews are examined in the context of Christian faith.

DFM742 Special Topics: Domestic Violence (1)

The topic of this workshop includes the effects of domestic violence on adults and children, practical counseling solutions, legal issues, and social factors of domestic violence in the context of Christian faith. Preventative strategies against domestic violence are explored.

DFM743 Special Topics: Psychopharmacology (2)

This topic discusses the various pharmaceutical drugs and their appropriate use in cooperation with counseling in the treatment of psychological disorders.

DFM744 Special Topics in Family Studies (4)

This course studies special topics as they relate to human development in the family system circle. These may include psychology of exceptional children, Alzheimer's disease, aging, memory loss, etc.

DFM750 Research Design (4)

This course covers research methods and principles in the area of the education of family. Human development birth to death will be covered. Content is specifically designed for designing a dissertation in the field of counseling and education. (Prerequisite: Research Methods)

DFM780/781 Advanced Field Experience I (3) and Advanced Field Experience II (3)

During the final year of study, students participate in an internship designed to give the student practical training experience under the direction of a competent and experienced pastor or Christian counselor. These practicums provide more intensive participation in the areas of family leadership and Christian counseling.

DFM790 Dissertations (8)

This course concentrates on writing the student's doctoral dissertation. The student will be required to develop a topic outline using the material developed in the methods seminar and then write the dissertation under the guidance of a faculty member.

DOCTOR OF EDUCATION IN CHRISTIAN EDUCATION

EDD701 Family Education and Counseling Research Design (4)

This course covers research methods and principles in the area of the marriage and family education and counseling. Content includes human development, from birth to death, for family education as well as various topics on marriage counseling. The students will have opportunity to learn how to research in the area of marriage and family education and counseling through qualitative and quantitative approaches. This course stimulates students to research for the dissertation proposal, integrating their interests and experiences.

EDD702 Special Topics in Family Studies (4)

This course studies special topics as they relate to human development in the family system circle. These may include psychological and/or theological research in current issues such as children, youth, couples, elders, and/or human development in the family system. Consulting with the professor, students will be able to recommend special topics related to their ministries and other topics in which they are interested.

EDD703 Advanced Child & Adolescent Counseling (4)

This course provides students practical skills in the area of child and adolescent education and counseling through experiential learning approaches. This course presents developmental theory for children so students are more effective in education and counseling. The students learn how to test the intellectual and personality traits of a child in order to have a basic understanding of him/her. This course examines normal and abnormal

behaviors, identifies common issues with counseling skills and techniques, which are most beneficial for children and adolescents.

EDD704 *Counseling Training Program Development* (4)

One of the objectives of the Ed.D. in Counseling program of HIS University is to train the students to be a director of counseling departments of their local churches and/or other organizations. The graduates are equipped with the knowledge and skills to train counselors. This course provides the students with a basic understanding of how to train effective counselors, lead in preparation of strategic plans and curriculum development.

EDD705 *Supervision Skills for Counselors* (4)

This course provides the students with the theories and skills to be a supervisor for counselors. Supervising is one of the essential elements in counselors' training process. It includes observation, evaluating, training, guiding and mentoring providing oversight to trainees using relational or systematic approaches for the purpose of helping them attain systemic clinical skills.

EDD710 *Advanced Adult and Senior Education and Counseling* (4)

This course examines in depth the current theories of adult and senior education including issues related to current literature. Emphasis will be placed on social and cultural issues while dealing from holistic aspects for producing the best results in adult and senior education and counseling.

EDD720 *Advanced Abnormal Psychology* (4)

This course explores the symptoms and causes of various types of psychological disorder, particularly the neurotic, psychotic, and mood disorders. A Psychodynamic understanding of these abnormal conditions is emphasized. How we define, assess, and study abnormality are important underlying issues. A variety of class exercise including small group activities, group discussion, group presentation, internet DVD, and DVDs are used to help students understand mental disorders.

EDD730 *Research Design* (4)

This course covers research methods and principles in the area of the education of family. Human development birth to death will be covered. Content is specifically designed for designing a dissertation in the field of counseling and education. (Prerequisite: Research Methods)

EDD780/781 *Advanced Field Practicum I* (3) and *Advanced Field Practicum II* (3)

During the final year of study, students participate in an internship designed to give the Christian Educator practical training experience under the direction of a competent and experienced pastor or Christian counselor. This practicum provides intensive participation in the areas of educational leadership and Christian counseling.

EDD790 *Dissertation* (8)

This course concentrates on writing the student's doctoral dissertation. The student will be required to develop a topic outline using the material developed in the methods seminar and then write the dissertation under the guidance of a faculty member.

MASTER OF ARTS IN MARRIAGE AND FAMILY MINISTRY

MFT500 *Research Methods* (3)

The course surveys the major social science research methods, preparing students to design and implement a testable research proposal and to review and utilize professional literature.

MFT509 *Philosophical Foundations of Psychotherapy* (3)

This course introduces students to the philosophical analysis of the anthropologies embedded within psychotherapeutic systems. Key issues in both the formation of moral selfhood and the development of a

biblical anthropology are identified. Students are encouraged to develop a view of human nature that demonstrates theological consistency and clinical applicability.

MFT510 *Cross-Cultural Education and Family* (3)

Advanced course dealing with marriage and family education and counseling integrated with principles and practices of cross-cultural education. It is an experiential learning approach to family ministry leaders' training designed to meet preventive and healing ministry in scriptural context.

MFT511 *Interpersonal and Intercultural Relationships* (3)

A study of the development and maintenance of healthy relationships. Topics of discussion include application of biblical principles to life situations, different personalities, development of skills in conflict management, and living in a group setting and being part of a team.

MFT512 *Legal, Ethical and Moral Issues in Therapy* (3)

This course introduces students to the moral foundations, ethical responsibilities, and California laws essential to the practice of clinical psychology and marital and family therapy. Ethical codes and the resolution of moral dilemmas are studied from the perspective of the Judeo-Christian ethical tradition.

MFT513 *Group Counseling* (3)

A study in learning theory related to group counseling. The course will introduce the art of helping others to gain deeper insight and better understand themselves through experiential learning exercises and assignments that include group feedback and results in modified behavior.

MFT514 *Marriage and Family Counseling* (3)

This course is an in-depth study of family structure, function, and dynamics from a family systems perspective in relation to family dysfunction and approaches to family intervention. Assessment techniques and analysis of marital relationships, with cultural variables influencing communication, human intimacy, and interpersonal dysfunctions are studied from different perspectives.

MFT540 *Special Topics: Child Abuse Workshop* (1)

This workshop fulfills the Board of Behavioral Sciences 7- hour training requirement on how to provide services to victims of child abuse. Also examined are contexts for child abuse, historical precedents and other sociological factors of child abuse and an examination of Christian faith and its response to child abuse.

MFT541 *Special Topics: Domestic Violence Workshop* (1)

The topics of this workshop include the effects of domestic violence on adults and children, practical counseling solutions, legal issues, and social factors of domestic violence in the context of Christian faith. Preventative strategies against domestic violence are explored.

MFT542 *Special Topics: Psychopharmacology* (2)

This topic discusses the various pharmaceutical drugs and their appropriate use in cooperation with counseling in the treatment of psychological disorders.

MFT543 *Special Topics: Aging and Long-term Care* (1)

This topic is required by the California Board of Behavioral Sciences (BBS) for the MFT license. This course related to taking care of seniors in aging and their aging related problems.

MFT551 *Theories of Personality and Psychotherapy* (3)

This course surveys the basic theoretical orientations used by current practitioners, focusing on theories used in treatment of individuals within a system. Established schools of thought will be studied and critiqued.

MFT552 *Human Sexuality and Sex Therapy* (3)

This course reviews human sexuality as a basis for sex therapy. Students examine and evaluate the biological, psychological, social, and moral perspectives of the theories of sexual development and functioning.

MFT557 Marital Therapy (3)

A study of the psychotherapeutic theories utilized in the clinical assessment and treatment of marital dysfunction is covered in this course. Models of a healthy marriage are also studied. Reading specific books and journal articles, as well as conducting a psychological assessment of couples is required.

MFT558 Advanced Developmental Psychology (3)

This course utilizes a lifespan perspective to consider individual development as it occurs within the family and family development as composed of individuals. Biological, psychological, social, and moral development are studied. Psychoanalytic, cognitive, and ecological systems models of development are presented.

MFT561 Child and Adolescent Therapy (3)

This course provides an understanding of the broad range of childhood and adolescent problems and disorders. A variety of psychotherapeutic modalities is presented, offering the student an opportunity to develop knowledge of basic child and adolescent therapy skills, assessments, and treatment strategies.

MFT563 Psychopathology (3)

This course provides a survey of the major theories, categories, and treatment of psychopathology. Through the use of case studies, students develop their diagnostic skills and a mastery of concepts in the Diagnostic and Statistical Manual of Mental Disorders.

MFT571 Family Therapy (3)

This course consists of an overview of current theories and methods of family intervention. The systems approach is emphasized, though psychodynamic and communication concepts in the interpersonal field are also included. The major theorists in each system are identified and their techniques demonstrated.

MFT577 Psychological Assessment Skills and Test (3)

This course provides students with a broad understanding of the clinical use of psychological tests, including projective personality tests, intelligence tests, and projective testing devices. Emphasis is placed on developing skills in interviewing, understanding and interpreting test data and reports, and gaining knowledge of referral questions, as well as writing integrated reports and providing feedback to examinees.

MFT580 Introduction to Clinical Practice I: Basic Skills (3)

This course introduces the student to basic skills in attending behavior, clinical interviewing, treatment planning, progress notes, clinical intervention, and medical/psychiatric consultation and referral.

MFT581 Introduction to Clinical Practice II: Advanced Skills (3)

This course is designed to further develop the psychotherapeutic skills of students prior to their entry into a clinical placement. Students focus on developing proficiency in the core interviewing qualities, deriving goals for clinical sessions, and in making contracts with clients for change.

MFT595 Special Topics: Alcoholism and Substance Abuse (1)

Special courses offer graduate level content that is typically scheduled in an intensive format. These courses include a range of specialized topics that are of interest to mental health professionals. Among these topics is the Substance Abuse Course. Courses range from 1 to 6 units depending upon the specific contact hours and workload involved in the course.

MFT596 Family Crisis Counseling (3)

Theoretical and practical issues of counseling families in crisis in the context of Christian experience are developed in this course.

MFT597/598 Clinical Placement I (3) and MFT Clinical Placement II (3)

During the final year of study, students participate weekly in a practice class, clinical field placement, and supervision session. In the classroom, students discuss and practice the clinical application of psychological theories to clients seen in their field placement. Students receive feedback from instructors and other students in response to role playing and audio/videotaped client sessions. In the clinical placement, students develop skills through direct treatment of individuals, couples, families, and children. Course I begins after the student has completed 12 units but no later than the first week of their final year of study.

MASTER OF ARTS IN CHRISTIAN COUNSELING

MCC500 *Research Methods* (3)

The course introduces the student to the process of scholarly inquiry in counseling, theology and ministry-related areas, including general, qualitative and quantitative research methodology. Also included is instruction on the preparation and presentation of academically researched papers and projects. Broad research approaches are examined. Special emphasis is given to the development of skills in using the library and its resources, and research writing. The course will include sample reading of counseling and theological literature and development of a model research paper.

MCC510 *Cross-Cultural Education and Family Ministry* (3)

Advanced course dealing with marriage and family education and counseling integrated to principles and practice of cross-cultural education. It is an experiential learning approach to family ministry leaders' training designed to meet preventive and healing ministry in a scriptural context.

MCC511 *Interpersonal and Intercultural Relationships* (3)

A study of the development and maintenance of healthy relationships. Topics of discussion include application of biblical principles to life situations, different personalities, development of skills in conflict management, and living in a group setting and being part of a team.

MCC514 *Christian Marriage and Family Counseling* (3)

This course is an in-depth study of family structure, function, and dynamics from a family systems perspective in relation to family dysfunction and approaches to family intervention. Assessment techniques and analysis of marital relationships, with cultural variables influencing communication, human intimacy, and interpersonal dysfunctions are studied from different perspectives.

MCC561 *Marital Counseling* (3)

This advanced course deals with problems and conflicts within marriage and family settings. Counseling methods and practical behavioral methods from a scriptural context designed to meet problems and conflicts; conducted via demonstrations, case studies and counseling involvement.

MCC518 *Human Growth and Development* (3)

An overview is provided regarding the theories and stages of human growth and development from birth to adulthood. This course examines the various stages of emotional, physical, sociological, cognitive, and spiritual growth.

MCC522 *Adolescent Psychology* (3)

This course studies the psychological growth processes of the adolescent. Included is an investigation of the theoretical and theological issues within the field of adolescent psychology.

MCC524 *Gender and Sexuality* (3)

This study provides a study of the relationships between social interaction processes and individual behaviors of the different genders of human beings. The course familiarizes the student with a variety of perspectives on social behavior and encourages the student to become a careful observer of social interaction through systematic research.

MCC532 *Communication Issues* (3)

A survey of the basic communication processes applied to human interaction. Various topics may include group communications, conflict resolution and leadership.

MCC533 *Cultural and Ethnic Issues* (3)

This course studies the A study of concepts, skills and attitudes useful in adapting to life in other cultures including inter-cultural communication, values, customs, etc.

MCC541 *Spirituality in Family Life* (3)

This course investigates the Biblical principles of family life. Values, mature religion, the nature of humanity, and religious experience are all areas of study for this purpose.

MCC545 *Family Therapy* (3)

This course studies the field of therapy for the family in crisis. Communication, conflict resolution, system analysis are the some of the various topics to be discussed.

MCC550 *Spirituality in Therapy* (3)

This course provides an investigation of the biblical principles concentrating on the mental health of the human adult. A common ground will be studied between psychology and the Christian faith.

MCC552 *Child Development* (3)

This course examines the stages of child development from birth to adolescence, placing emphasis on the development problems that exhibit during treatment and therapy.

MCC555 *Child and Youth Counseling* (3)

This course will examine the emotional, cognitive, physical and social development from infancy through adolescence. Theories and research on the helping relationships towards children and youth are explored.

MCC560 *Christian Counseling and Psychotherapy* (3)

This course provides the students with general understanding of the integration between Christian counseling and psychotherapy. The classes focus is on the analytical psychology of Jung as it relates to Christian integrity based on the Bible. This course also deals with the relationship of the fields of psychology, theology and Christian spirituality. It will explore the role of Biblical principles as related to human psychotherapy and the mental health field.

MCC565 *Group Counseling* (3)

The principles, dynamics and techniques of group therapy are examined. The focus will be on experiential, theoretical and practical aspects of group dynamics, processes and methodologies available to the family counselor. Special attention will be given to the developmental stages of groups and examining some of the facilitating roles of the leader.

MCC563 *Theories of Psychotherapy* (3)

This course will examine the variety of psychotherapeutic orientations directly related to marriage and family therapy approaches to treatment.

MCC564 *Abnormal Psychology* (3)

A course which examines the theories and issues of psychological maladies. Counseling and medical treatment is considered from the perspective of Christian worldview.

MCC570 *Practicum I* (3)

This course will give field work experience to the student. It provides intern placement in a professional setting.

MCC571 *Practicum II* (3)

This course will continue the fieldwork experience to the student. Additional integration of knowledge, skills and values as well as opportunities to assist the student in identifying personal and professional interests which will be of use in career decisions.

MASTER OF ARTS IN CHRISTIAN EDUCATION

MCE500 *Research Methods* (3)

The course introduces the student to the process of scholarly inquiry in counseling, theology and ministry-related areas, including general, qualitative and quantitative research methodology. Also included is instruction on the preparation and presentation of academically researched papers and projects. Broad research approaches are examined. Special emphasis is given to the development of skills in using the library and its resources, and research writing. The course will include sample reading of counseling and theological literature and development of a model research paper.

MCE501 *Introduction to Christian Education* (3)

A comprehensive treatment of the significance and scope of Christian Education: its definition nature, objectives, and procedures. This course will survey the field of Christian Education as applied in a local church setting.

MCE502 *Biblical Foundations of Christian Education* (3)

A study of the Biblical principles of Christian Education and the role they play in the local church setting.

MCE503 *Christian Philosophy of Education* (3)

This course studies the major religions and secular developments in the philosophy of education. A comparison of those developments with biblical principles to develop an understanding of the church's role in education is provided.

MCE510 *Cross-Cultural Education and Family Ministry* (3)

Advanced course dealing with marriage and family education and counseling integrated to principles and practice of cross-cultural education. Experiential learning approach to family ministry leaders' training designed to meet preventive and healing ministry in a scriptural context.

MCE511 *Interpersonal and Intercultural Relationships* (3)

This course studies the development and maintenance of healthy relationship. Topics of discussion include application of Biblical principles to life situations, different personalities, development of skills in conflict management, and living in a group setting and being part of a team.

MCE512 *Christian Family Life Education* (3)

A course designed for students to learn biblical family education in the Christian setting. Included is an emphasis on biblical principles of family and ways to apply biblical teaching in daily life.

MCE513 *Child and Youth Education* (3)

A study of the basic principles underlying ministry to children and basic ministry principles and strategies to youth, ages 13-21, in the local church setting.

MCE514 *Christian Marriage & Family Education* (3)

This course is an in-depth study of the definition, structure, function, theology and dynamics of family systems in relation to marriage and family education based on a Biblical foundation. From premarital education to marital relationships and parenting education, this course is focused on cultural variables related to communication, human intimacy and interpersonal dysfunctions studied from different perspectives. Topics include the various issues and crises such as mid-life crisis, divorce, death and long-term care in marriage and family life education.

MCE520 Parenting Education (3)

This course studies principles in good parenting skills. Included are concepts of the mental, physical and emotional development of children.

MCE521 Child and Adolescent Development Psychology (3)

A study of the psychological growth processes of children and adolescents. Included is an investigation of the theoretical and theological issues within the field of psychology.

MCE522 Adolescent Psychology (3)

A study of the psychological growth processes of the adolescent. Included is an investigation of the theoretical and theological issues within the field of adolescent psychology.

MCE530 Child and Family Development (3)

The study of human development across the life span which emphasizes a multidisciplinary perspective including such areas as psychology, sociology, processes as social interaction, and the tools for applying developmental psychology to life situations.

MCE533 Cultural and Ethnic Issues (3)

This course studies the concepts, skills and attitudes useful in adapting to life in other cultures, including intercultural communication, values, customs, etc.

MCE570 Field Education (3)

An internship course designed to give potential Christian Education leadership and minister's practical training experience under the direction of a competent and experienced pastor or counselor.

BACHELOR OF ARTS IN COUNSELING

BA 220 New Testament Survey (3)

This course surveys the complete New Testament inclusive of the historical and cultural context including the Intertestamental period in order to gain knowledge of the life of Christ, the establishment of the church, and the teachings concerning the believer's faith and practice.

BA 230 Old Testament Survey (3)

The purpose of Old Testament Survey is to general introduction to the Old Testament books. Emphasis is placed upon gaining an overview of the Old Testament through a survey of geographical and historical backgrounds and a book-by-book study. Attention is given to the structure of each biblical book, significant interpretative problems, and major theological themes. This course has no prerequisite courses.

BAC 300 Introduction to Research Methods (3)

Research skills for use of the internet, library and reference works in counseling and Bible. Methods of writing with emphasis on critical thinking, persuasion and evaluation are covered, culminating in research paper written in APA style and oral presentation.

BAC 310 Foundations of Christian Counseling (3)

This course explores developments within the Christian counseling movement. It examines the nature of the client and the counselor as well as various settings in which counseling skills may be used. Methods of gathering useful data are examined. General methods in group and individual counseling are discussed with emphasis on self-awareness development, characteristics and techniques to be used by the counselor in interviewing and counseling in Christian, secular and multicultural environments.

BAC311 Premarital Counseling (3)

A study of compatibility and readiness for marriage. Focus is placed on areas to explore with couples either prior to or after engagement. This course includes an introduction to the assessment tools most commonly used in premarital counseling.

BAC312 *Biblical Foundations of Marriage and Family* (3)

A psychologically and theologically integrated study of marriage and family relationships, prepares students to develop a personal philosophy of family and to set the foundation for the development of a family ministry within the church. The course includes a personal evaluation of student's familial experiences and a challenging look at cultural norms and biblical principles. This skill building course prepares students for participation in leadership of family life.

BAC320 *Introduction to Child Counseling* (3)

This course provides an introduction to the basics of counseling children. The course will emphasize a survey of developmentally appropriate individual and systemic counseling approaches for children.

BAC321 *Introduction to Adolescent Counseling* (3)

This course is an introduction to the basics of counseling adolescents. The course will emphasize a survey of developmentally appropriate individual and experiential counseling approaches for adolescents.

BAC330 *Counseling Seminar* (3)

The student will participate in a conference on current issues in counseling. The professor will choose from a variety of Christian counseling and psychology conferences available which one the students will attend. Conference fees are paid in addition to student tuition.

BAC331 *Special Topics in Counseling* (3)

Numerous available workshops providing foundations for a variety of counseling topics such as child and spousal abuse, alcoholism and substance abuse, domestic violence, crisis counseling and others. Workshops change from semester to semester.

BAC350 *Introduction to Psychology* (3)

This is a survey of psychology as an empirical/behavioral science with a consideration of underlying philosophical bases in light of a Christian world view. Topics to be surveyed include development, cognition, learning, motivation, physiology, socialization, personality and psychopathology.

BAC451 *Developmental Psychology* (3)

This course is a study of the theory and research concerning lifespan development. Consideration will be given to the physical, emotional, cognitive, social and moral aspects of human development across the entire span from conception to death. Discussion will include timely issues of personal relevance to the student's own developmental pathway.

BAC452 *Abnormal Psychology* (3)

This course examines the nature, causes and treatment of abnormal behavior, including the full range of mental disorders identified within current categorical systems.

BAC460 *Human Relationship* (3)

An explanation of humanity's relational nature as it reflects God's relational nature. Health in a variety of relational contexts will be explored. Self-awareness as well as implications of ministry to others is emphasized.

BAC470 *Personality Theory* (3)

An overview of personality theories including the primary representatives of the major schools: analytic or dynamic, humanistic-existential and behavioral. An integrative model will also be presented.

BAC480 *Foundations of Psychotherapy* (3)

This course provides an introduction to the theory and techniques of psychotherapy. It includes an overview of various approaches to psychotherapy and a discussion of foundational therapeutic techniques.

ASSOCIATE OF ARTS IN COUNSELING

AAD262 *Communication Skills* (3)

This course provides the students with the basic and practical skills for communication emphasizing on interview skills as the basic of counseling. Verbal and non-verbal communication skills are included. The students learn how to have creative and healthy way of communication with family members, friends, co-workers and clients in the private and public arena.

AAD263 *Introduction to Abnormal Psychology* (3)

This course explores the symptoms and causes of various types of psychological disorders – particularly the neurotic, psychotic, and mood disorders. A psychodynamic understanding of these abnormal conditions is emphasized. How we define, assess, and study abnormality are important underlying issues. A variety of class exercise – including small group activities, group discussion, group presentation, internet DVD, and visitation the sites such as NAMI (National Alliance of Mental Illness), Village and/or some agencies or facilities.

AAD264 *Introduction to Human Relationships* (3)

This course provides for student learning in the arena of practical skills in human relationships through the experiential learning approach. Basic theory and principles of interpersonal relationships are presented. Students learn how to understand, to accept, and to appreciate differences from their own perspectives. Topics of discussion include application of different personalities, development skills in conflict management and living in a group setting and being part of a team. The students have an opportunity to understand themselves and others as a basic foundation of counseling.

AAD265 *Child and Youth Counseling* (3)

This course provides students with the basic knowledge and information about child and youth developmental theories, equipping them with education and tools for counseling children and youth. Students will understand children and youth according to their developmental stages and be able to assess them as to their development and growth into healthy adults physically, mentally, socially and spiritually through this course.

AAD266 *Marriage and Family Counseling* (3)

This course is in-depth study of family structure, function, and dynamics from a family systems perspective in relation to marriage and family counseling based on the biblical principles. Assessment and techniques and analysis of marital relationships, with cultural variables including communication, human intimacy, and interpersonal dysfunctions, are studied from different perspectives.

AAD267 *Legal, Ethical and Moral Issues in Counseling* (3)

This course introduces students to moral foundations, ethical responsibilities, and California laws essential to the practice of counseling for children and youth. Ethical codes and the resolution of moral dilemmas are studied from the perspective of the Biblical ethical standards. This course deals with child abuse, domestic violence and other mandatory report issues according to the California laws on the mental health professionals.

AAD271 *Practicum I* (2)

Counselors need to have positive and healthy self-identification without unfinished business in their lives. Through this course, students have the opportunity to experience themselves being counseled as clients by professional, licensed counselors. The students will be able to learn the attitude and hearts of the counselors by their own experiences as clients.

AAD272 *Practicum II* (2)

Students majoring in counseling need field experience under the supervision of a qualified supervisor. The practicum sites may include agencies providing counseling services, nursery, preschool, kindergarten, private and public schools, and/or Sunday schools of local churches, mental health providers' private and public facilities with the school administration approval. Students will be evaluated by the site directors on their practicum and students will evaluate the site and their services according to their learning standards.

AAD281 *Play Therapy* (3)

Play therapy requires special knowledge and skills because of its unique theories and counseling skills. Children and youth counselors need to understand and to learn basic theories and skills training to enable a more effective counseling process. This course presents an overview of play therapy and its skills so that students will

be motivated and challenged to learn more with awareness of their training needs. Students will understand the basic knowledge and skills of play therapy and will interact with research sources and information related to play therapy through this course.

AAD283 *Marital Therapy* (3)

This course deals with problems and conflicts within marriage and family settings using counseling methods and practical behavioral methods from a scriptural context designed to meet problems and conflicts conducted via demonstrations, case studies and counseling intervention. Students will learn how to counsel couples with marital conflicts through the experiential learning approach.

AAD286 *Parenting Education and Counseling* (3)

Children and youth counselors need to learn the basic principles and skills of parenting in order to help parents raise their children in more effective and healthy ways. This course provides students with the biblical way of raising children and psychological integration with parenting skills. Students will gain some insight and research foundations to be able to prepare and teach a parenting class in the setting of a local church.

DIPLOMA IN PEER COUNSELING

DCC101 *Basic Counseling Skills* (3)

This is an introduction to the study of human behavior and the development and maintenance of healthy relationships. Theories and research on the helping relationships are explored.

DCC102 *Christian Counseling and Life Development* (3)

This course is designed to study the development and maintenance of healthy relationships. Topics of discussion include application of Biblical principles to life situations different personalities, development of skills in conflict management, living in a group setting and being part of a team.

DCC103 *Christian Marriage and Family Counseling* (3)

This is a study of the biblical principles of marriage and family and students learn how to counsel those in crisis.

DCC104 *Communication Skills* (3)

This course studies the elements of communicating in the private and public arena.

DCC105 *Family Therapy* (3)

This is a study and practical application of biblical and counseling techniques in the family counseling arena.

DCC140 *Special Topics: Child Abuse Workshop* (1)

This workshop fulfills the Board of Behavioral Sciences 7- hour requirement for training on ways to provide services to victims of child abuse. Also examined are contexts for child abuse, historical precedents and other sociological factors of child abuse and an examination of Christian faith and its response to child abuse.

DCC141 *Special Topics: Alcoholism and Substance Abuse* (3)

Special courses offer graduate level content that is typically scheduled in an intensive format. These courses include a range of specialized topics that are of interest to mental health professionals. Among these topics is the Substance Abuse Course. Courses range from 1 to 6 units depending upon the specific contact hours and workload involved in the course.

DCC142 *Special Topics: Domestic Violence Workshop* (1)

The topics of this workshop include the effects of domestic violence on adults and children, practical counseling solutions, legal issues, and social factors of domestic violence in the context of Christian faith. Preventative strategies against domestic violence are explored.

DCC143 *Special Topics: Psychopharmacology* (2)

This topic discusses the various pharmaceutical drugs and their appropriate use in cooperation with counseling in the treatment of psychological disorders.

DCC 180 Practicum (3)

This course gives fieldwork experience to the student. It provides intern placement in a professional setting. The aim is to provide an opportunity for the integration of knowledge, skills, and values as well as opportunities to assist the student in identifying personal and professional interests which will be of use in career decisions.

DCC 511 Interpersonal and Intercultural Relationships (3)

This course studies the development and maintenance of healthy relationships. Topics of discussion include application of biblical principles to life situations, different personalities, development of skills in conflict management, and living in a group setting and being part of a team.

DCC520 Parenting Education (3)

This course studies the principles in good parenting skills. Included are concepts related to the mental, physical and emotional development of children.

DCC533 Child and Adolescent Therapy (3)

This course provides an understanding of the broad range of childhood and adolescent problems and disorders. A variety of psychotherapeutic modalities is presented, offering the student an opportunity to develop knowledge of basic child and adolescent therapy skills, assessments, and treatment strategies.

DCC556 Group Counseling (3)

The principles, dynamics and techniques of group therapy are examined. The focus will be on experiential, theoretical and practical aspects of group dynamics, processes and methodologies available to the family counselor. Special attention will be given to the developmental stages of groups and examining some of the facilitating roles of the leader.

DCC560 Christian Counseling and Psychotherapy (3)

This course will examine the common bond between psychology and the Christian faith. It will explore the role of biblical principles as related to human psychotherapy and the health field.

Admission and Evaluation Process of Foreign Students

To be enrolled, an admitted candidate must do the following:

1) **Process of Admission**

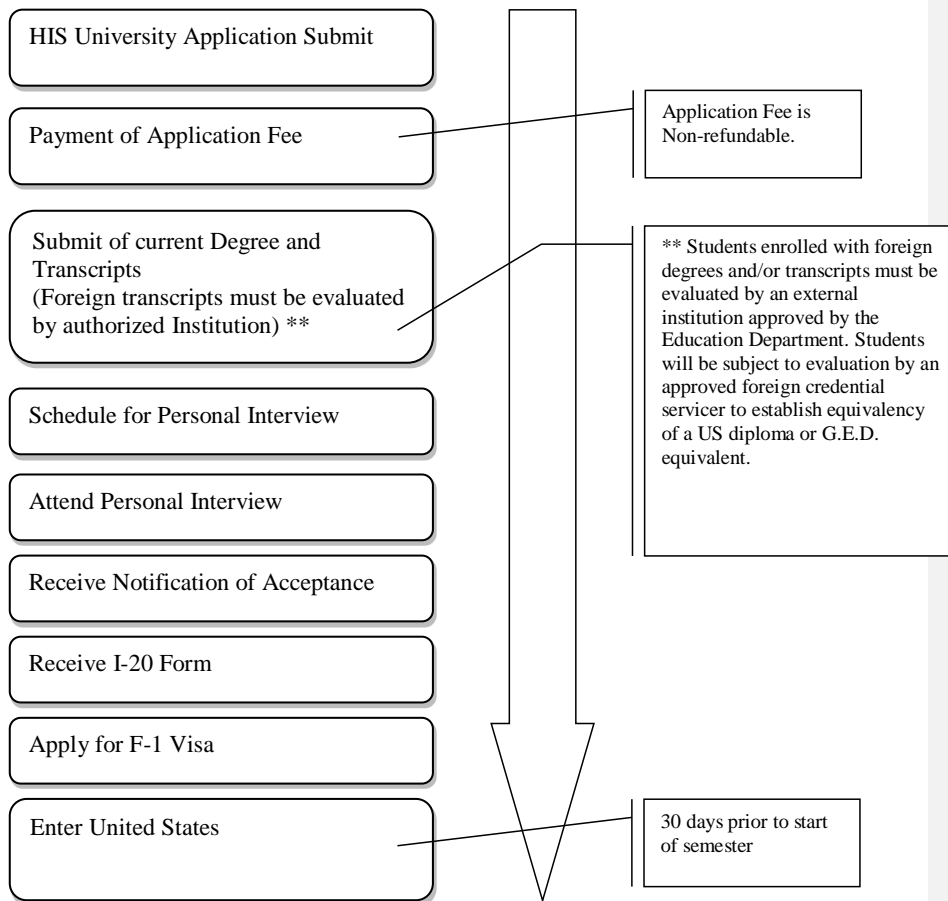

Admission and Evaluation Process of Foreign Students

To be enrolled, an admitted candidate must do the following:

2) Required Documentation

Ph.D. in Family Ministry
- HIS University Application

- Master's Degree and Official Transcripts from institutions outside of the US
(These must be evaluated by an approved foreign credential servicer)
- Two letters of Recommendation
- Personal Introduction
- Experience Evidence in the area of family ministry more than three years

Ed.D in Counseling

- HIS University Application
- Master's Degree and Official Transcripts from institutions outside of the US
(These must be evaluated by an approved foreign credential servicer)
- Two letters of Recommendation
- Personal Introduction

Master's Degree

- HIS University Application
- Bachelor's Degree and Official Transcripts (evaluated by a HIS University official)
- Two letters of Recommendation
- Personal Introduction
- English Proficiency Test Scores (TOEFL score over 80: M.A. in MFT only)

Bachelor's Degree

- HIS University Application
- High School Diploma (evaluated by a HIS University official)
OR an AA degree and Official Transcripts or equivalent (evaluated by a HIS University official)
- Two letters of Recommendation
- Personal Introduction

Associate's Degree

- HIS University Application
- High School Diploma (evaluated by a HIS University official)
- Personal Introduction

Diploma

- HIS University Application
- High School Diploma (evaluated by a HIS University official)
- Personal Introduction

HIS UNIVERSITY CAMPUS MAP

1st Floor

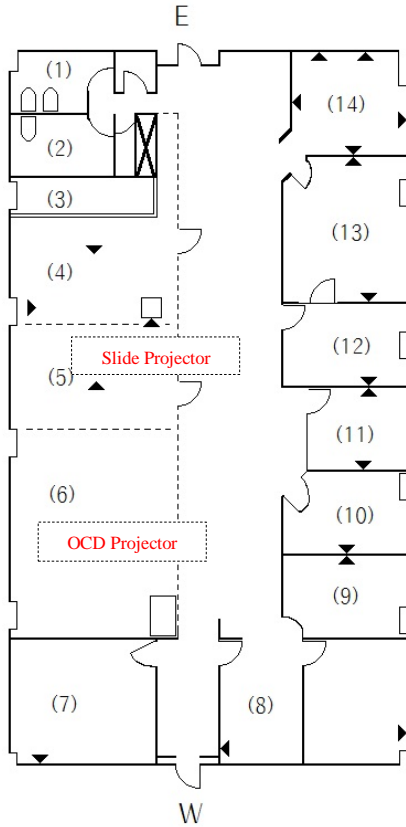

2nd Floor

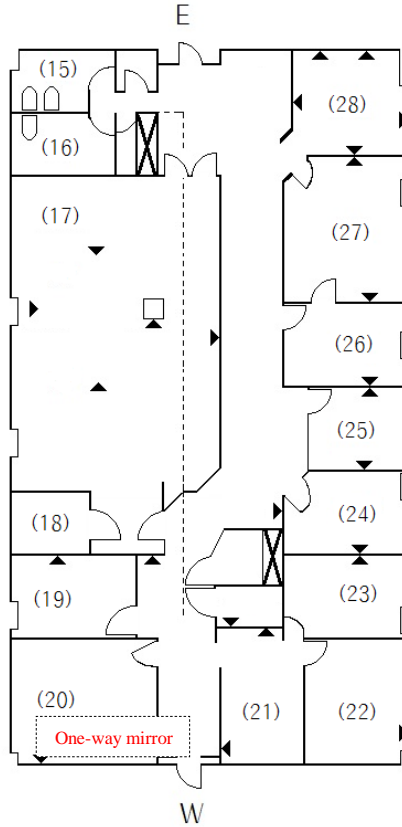

ROOM (Equipment and Material)

- | | | | |
|----------------------------------|-----------------------------|--|---------------------|
| (1) Women's Restroom | (11) Korean Library | (15) Women's Restroom | (25) Faculty Room |
| (2) Men's Restroom | (12) Counseling Room | (16) Men's Restroom | (26) Faculty Room |
| (3) Storage | (13) Family Counseling Room | (17) Seminar Room 201 | (27) Office Lounge |
| (4) Counseling Room 112 | (14) Digital Library 101 | (18) Kitchen | (28) Reception Desk |
| (5) Class Room (Slide Projector) | | (19) Faculty Room | |
| (6) Class Room 110 (Projector) | | (20) Meeting Room 204 (One way mirror) | |
| (7) Counseling Room 109 | | (21) Play Therapy Room 205 (Yarn game material) | |
| (8) Counseling Office | | (22) Counseling Room 206 (Play money Material) | |
| (9) Student Lounge | | (23) Counseling Room (Dolls and figure material) | |
| (10) Computer Room | | (24) Meeting Room | |

COMMUNITY AGREEMENTS

Biblically speaking, the following behavioral expectations apply to all members of the HIS University community:

1. Those acts, which are expressly forbidden in Scripture, including: premarital/extramarital sex, homosexuality, drunkenness, theft, profanity, occult practices, and dishonesty will not be practiced by members of this community.
2. Other areas the community is expected to avoid are known as “sins of the spirit” and “sins of the tongue.” These include such sins as covetousness, jealousy, pride, lust, envy, immodesty, impatience, backbiting, enmity, strife, outbursts of anger, factions, bitterness, an unforgiving spirit, slander, discrimination and prejudice (Jeremiah 9:3-9, Mark 7:20-23, Galatians 5:12-21). Although these issues are more difficult to discern, they can be destructive to the healthy functioning of the community.
3. Recognizing the Christian obligation to submit to the governing authorities (Romans 13:1, 1 Peter 2:13), individuals related to HIS University are expected to uphold the laws of the local community, the state and the nation.

In addition to those behaviors and attitudes which the Scriptures specifically praise or condemn, the HIS Board has adopted the following statement of community agreements which are a requirement for membership in the HIS community.

HIS University is a community of Christians committed to the principles of Christian living found in the Bible and holds that these biblical standards are vital to our individual and corporate relationships. Maintaining these standards contributes to the kind of atmosphere in which quality Christian and secular communities. In this light, and given the clear biblical imperative for spiritual self-discipline, the university has established these “standards of conduct” to be observed and upheld, by all members of the HIS community.

Consistent with the example and command of Jesus Christ, we believe that life within a Christian community must be lived to the glory of God, with love for God and for our neighbors. Being indwelt by the Holy Spirit, we strive to walk by the Spirit, “crucifying the flesh with its passions and desires” (Galatians 5:24). To this end, members of the HIS community are not to engage in activities which Scripture forbids. Such activities include, but are not limited to, dishonesty, thievery, fornication, adultery, homosexual practice, drunkenness and unscriptural divorce. Scripture also condemns other “deeds of the flesh” such as covetousness, jealousy, pride and lust – sins which the maturing Christian should put off, and replace with the “fruit of the Spirit”: Love, joy, peace, patience, kindness, goodness, faithfulness, gentleness and self-control (e.g., Luke 10:27; Galatians 2:20, 5:14-24; Ephesians 2:3; 1 Corinthians 6:9-10).

As a Christian educational institution, HIS also recognized the responsibility of its board of trustees, faculty and staff to provide examples of maturing Christian character conduct to its students and the community at large. To this end, participation in certain practices has been traditionally held by the University to be inappropriate for members of the HIS community. Such practices relate to areas of personal discipline and are in keeping with the biblical admonition that Christians glorify God in their physical bodies as “the temple of the Holy Spirit” (1 Corinthians 6:19-20), and that their freedom in Christ must not cause a brother or sister in Christ to stumble (1 Corinthians 8:7-13; 10:23-33). Members of the HIS community are expected to refrain from the use of alcoholic beverages and tobacco in any form, and from gambling. Also, HIS does not allow social dancing and university-related or sponsored activities (that is, at any activities that involved any identifiable university group, is publicized on campus and/or has the appearance of being university-related, whether held on or off campus). HIS University does not presume to be a censoring agency for all activities; however, it does expect tangible evidence of maturing Christian convictions and discerning judgment.

In addition, members of the HIS community will observe Sunday as the Lord’s Day and give primary attention to worship, rest, Christian fellowship and recreation and service.

These standards apply to the student while enrolled in any of the schools or programs of the university on and off campus. In addition, these standards apply to the board members during their terms of service on the HIS University Board, and to faculty and staff during their terms of employment with HIS University. HIS therefore reserves the right to discipline or dismiss any student or employee who, in its judgment, does not conform to these conduct standards or to other expressed principles, policies, programs and expectations of the university governing employee conduct.

HIS UNIVERSITY'S FAITH STATEMENT

Inasmuch as the University is interdenominational and yet theologically conservative, a doctrinal statement is given below:

The Bible, consisting of all the books of the Old and New Testaments, is the Word of God, a supernaturally given revelation from God Himself, concerning Himself, His being, nature, character, will and purposes; and concerning man, his nature, need and duty and destiny. The Scriptures of the Old and New Testaments are without error or misstatement in their moral and spiritual teaching and record of historical facts. They are without error or defect of any kind.

There is one God, eternally existing and manifesting Himself to us in three Persons – Father, Son and Holy Spirit.

Our Lord Jesus was supernaturally conceived by the power of the Holy Spirit and born of a virgin – Mary, a lineal descendant of David. He lived and taught and did mighty works and wonders and signs exactly as is recorded in the four Gospels. He was put to death by crucifixion under Pontius Pilate. God raised from the dead the body that had been nailed to the cross. The Lord Jesus after His crucifixion showed Himself to be alive to His disciples, appearing to them by the space of 40 days after his resurrection. After this, the Lord Jesus ascended into heaven, and the Father caused Him to sit at His right hand in the heavenly places, far above all rule and authority and power and dominion, and every name that is named, not only in this world, but also in the world, which is to come, and put all things in subjection under His feet, and gave Him to be Head over all things to the Church.

The Lord Jesus, before His incarnation, existed in the form of God and His own choice laid aside His divine glory and took upon himself the form of a servant and was made in the likeness of men. In His pre-existent state, He was with God and was God. He is a divine person possessed of all the attributes of Deity, and should be worshiped as God by angels and man. "In Him dwells all the fullness of the God head bodily." All the words that He spoke during His earthly life were the words of God. There is absolutely no error of any kind in them, and by the words of Jesus Christ the words of all other teachers must be tested.

The Lord Jesus became in every respect a real man, possessed of all the essential characteristics of human nature.

By His death on the cross, the Lord Jesus made a perfect atonement for sin, by which the wrath of God against sinners is appeased and a ground furnished upon which God can deal in mercy with sinners. He redeemed us from the curse of the law by becoming a curse in our place. He who Himself was absolutely without sin was made to be sin on our behalf that we might become the righteousness of God in Him. The Lord Jesus is coming again to his earth, personally, bodily, and visibly. The return of our Lord is the blessed hope of the believer, and in it God's purposes of grace toward mankind will find their consummation.

The Holy Spirit is a person, and is possessed of all the distinctively divine attributes. He is God.

Man was created in the image of God, after His likeness, but the whole human race fell in the fall of the first Adam. All men, until they accept the Lord Jesus as their personal Savior, are lost, darkened in their understanding, alienated from the life of God through the ignorance that is in them, hardened in heart, morally and spiritually dead through their trespasses and sins. They cannot see, nor enter the Kingdom of God until they are born again of the Holy Spirit.

Men are justified on the simple and single ground of the shed blood of Christ and upon the simple and single condition of faith in Him who shed the blood, and are born again by the quickening, renewing, cleansing work of the Holy Spirit, through the instrumentality of the Word of God.

All those who receive Jesus Christ as their Savior and their Lord, and who confess Him as such before their fellow men, become children of God and receive eternal life. They become heirs of God and joint-heirs with Jesus Christ. At death their spirits depart to be with Christ in conscious blessedness, and the Second coming of Christ their bodies shall be raised and transformed into the likeness of the body of His glory.

All those who persistently reject Jesus Christ in the present life shall be raised from the dead and throughout eternity exist in the state of conscious, unutterable, endless torment and anguish.

The Church consists of all those who, in this present dispensation, truly believe in Jesus Christ. It is the body and bride of Christ, which Christ loves and for which He has given Himself.

There is a personal devil, a being of great cunning and power: "The prince of the power of the air," "The prince of this world," "The god of this age." He can exert vast power only so far as God suffers him to do so. He shall ultimately be cast into the lake of fire and brimstone and shall be tormented day and night forever.

Note: This doctrinal statement, presented here as originally written, has been and continues to be the stated theological position of HIS University. Where "man" is used, referring to the human race, it includes both genders. In addition, the following explanatory notes indicate the organization's understanding and teaching position on certain points, which could be subject to various interpretations:

- The Scriptures are to be interpreted according to the conviction that the return of the Lord for His Church will be premillennial, before the Tribulation.
- The existence of the Creation is not explainable apart from the roles of God as the sovereign Creator and Sustainer of the entire natural realm. Concepts such as theistic or threshold evolution do not adequately explain creation.
- Though there may be many fillings of the Holy Spirit, there is only one baptism, which occurs at the time of regeneration. The gifts of the Spirit are given to believers according to the will of God for the purpose of building up the Church. During the foundational era of the Church (i.e., the time of Christ and the Apostles) God gave special manifestations of the overtly supernatural and miraculous gifts (e.g., tongues, healings, miracles) as "signs" that witness to the validity of those bearing new canonical revelation (c.f. 2 Cor. 12:12; Heb. 2:3-4). Beyond the foundational era, God in His sovereignty may grant any spiritual gift and work miraculously for the benefit of His Church at any time.
- The Bible is clear in its teaching on the sanctity of human life. Life begins at conception. We abhor the destruction of innocent life through abortion-on-demand.
- Confession before men is viewed as tangible fruit of salvation and not as a qualifying condition for salvation.